

EN	Setup Guide	For detailed information and safety recommendations, refer to the User's Manual (installed with the software).
DE	Installationshandbuch	Ausführliche Informationen und Sicherheitshinweise finden Sie im Benutzerhandbuch (welches mit der Software installiert wird).
FR	Guide d'installation	Pour plus d'informations et pour les recommandations de sécurité, référez-vous au Manuel de l'utilisateur (installé avec le logiciel).
IT	Guida di installazione	Per informazioni dettagliate e raccomandazioni di sicurezza, consultare il Manuale dell'utente (installato con il software).
ES	Guía de instalación	Para obtener información detallada y recomendaciones de seguridad, consulte el Manual del usuario (instalado con el software).
PT	Manual de instalação	Para obter informações e recomendações de segurança detalhadas, consulte o Manual do Utilizador (instalado com o software).
NL	Installatiehandleiding	Raadpleeg de Gebruikershandleiding (geïnstalleerd met de software) voor gedetailleerde informatie en veiligheidsaanbevelingen.
DA	Installationsvejledning	Se Brugervejledningen (installeret sammen med softwaren) for detaljerede oplysninger og sikkerhedsanbefalinger.
FI	Asennusopas	Katso tarkat tiedot ja turvallisuussuosituksset (ohjelmiston mukana asentuvasta) Käyttöohjeesta.
NO	Installeringshåndbok	Hvis du vil ha detaljert informasjon og sikkerhetsanbefalinger, kan du gå til brukerhåndboken (installeres sammen med programvaren).
SV	Installationshandbok	Mer information och säkerhetsföreskrifter finns i enhetens användarhandbok (installeras tillsammans med programvaran).
CS	Instalační příručka	Podrobné informace a bezpečnostní doporučení viz Uživatelská příručka (nainstalovaná se softwarem).

HU	Üzembe helyezési útmutató	A részletes információkat és a biztonsági figyelmeztetéseket a (szoftverrel együtt telepített) Felhasználói útmutató tartalmazza.
TR	Kurulum kılavuzu	Ayrıntılı bilgi ve güvenlik önerileri için Kullanma Kılavuzuna (yazılım ile yüklenmiştir) bakınız.
SL	Priročnik za namestitev	Za podrobne informacije in varnostna priporočila glejte Uporabniški priročnik (nameščen s programsko opremo).
HR	Vodič za postavu	Podrobne informacije i savjete za sigurnost pogledajte u uputama za uporabu (instaliranom zajedno sa softverom).
RU	Руководство по установке	Подробная информация и рекомендации по технике безопасности приводятся в документе "Руководство по эксплуатации" (устанавливается вместе с программным обеспечением).
SC	安裝指南	有关详细说明和 safety 注意事项，请参阅随软件一起安装的使用说明书。
TC	安裝指南	有關詳細說明和 safety 注意事項，請參閱隨軟體一起安裝的使用說明書。
HK	安裝指南	有關詳細資訊和 safety 建議，請參閱使用說明書（用於軟體安裝）。
KO	설치 안내	상세 정보 및 안전 권장 사항에 대해서는 소프트웨어와 함께 설치되는 취급 설명서를 참조하십시오.
TH	ข้อแนะนำการติดตั้ง	สำหรับข้อมูลที่ละเอียดและข้อแนะนำด้านความปลอดภัย อ่างอิงคู่มือการใช้งาน (ได้รับการติดตั้งด้วยซอฟต์แวร์)
VI	Hướng dẫn Cài đặt	Để biết thêm thông tin chi tiết và những khuyến nghị về an toàn, hãy xem Sách Hướng dẫn Người sử dụng (được cài đặt cùng với phần mềm).
JA	セットアップガイド	詳しい説明や安全上のご注意は、ソフトウェアと一緒にインストールされるユーザーズマニュアルをご覧ください。

DE: Maschinenlärminformations-Verordnung 3. GPSGV: Der höchste Schalldruckpegel beträgt 70 dB(A) oder weniger gemäß EN ISO 7779.

Das Gerät ist nicht für die Benutzung im unmittelbaren Gesichtsfeld am Bildschirmarbeitsplatz vorgesehen. Um störende Reflexionen am Bildschirmarbeitsplatz zu vermeiden, darf dieses Produkt nicht im unmittelbaren Gesichtsfeld platziert werden.

Indication of the manufacturer and the importer in accordance with requirements of directive 2011/65/ EU (RoHS)

Manufacturer: SEIKO EPSON CORPORATION
Address: 3-5, Owa 3-chome, Suwa-shi, Nagano-ken 392-8502, Japan
Telephone: 81-266-52-3131 Fax: 81-266-52-8409

Importer: EPSON EUROPE B.V.
Address: Azië building, Atlas ArenA, Hoogoorddreef 5, 1101 BA Amsterdam Zuidooost, The Netherlands
Telephone: 31-20-314-5000

製造商：精工愛普生株式会社
地址：日本東京都新宿区西新宿 2-4-1

Printed in China
中国印刷
Copyright © 2009 by Seiko Epson Corporation. All rights reserved. 20120928

EN
Depending on the model, the accessories in the broken line box may not be included. The shape of the accessories varies between models and areas.

DE
Je nach Modell ist das Zubehör in dem mit gestrichelten Linien umrandeten Kästchen möglicherweise nicht inbegriffen. Das äußere Erscheinungsbild des Zubehörs ist von Modell und Region abhängig.

FR
En fonction du modèle, il se peut que les accessoires représentés dans le cadre formé par une ligne discontinue ne soient pas fournis. La forme des accessoires varie d'un modèle et d'un pays à l'autre.

IT
A seconda del modello, gli accessori presenti nel riquadro tratteggiato potrebbero non essere inclusi. La forma degli accessori varia tra modelli e aree.

ES
En función del modelo, los accesorios en el cuadro con la línea discontinua pueden no estar incluidos. La forma de los accesorios varía según el modelo y el área.

PT
Dependendo do modelo, os acessórios na secção picotada poderão não estar incluídos. O formato dos acessórios varia consoante os modelos e zonas.

NL
Afhankelijk van het model is het mogelijk dat de accessoires die u in het vak met de ononderbroken rand ziet, niet zijn meegeleverd. De vorm van de accessoires varieert volgens het model en het gebied.

DA
Afhængigt af modellen, er tilbehøret i boksen med den stiplede linje muligvis ikke inkluderet. Formen på tilbehøret er forskellig, alt efter model og område.

FI
Katkoviivalla merkityssä laatikossa olevia lisävarusteita ei toimiteta välttämättä kaikkien mallien mukana. Lisävarusteiden muoto voi vaihdella mallin ja alueen mukaan.

NO
Avhengig av modellen kan det hende at tilbehøret i boksen med den stiplede linjen, ikke er inkludert. Formen på tilbehøret varierer alt etter modell og område.

SV
Tillbehören i rutan med den streckade linjen kanske inte medföljer beroende på modellen. Tillbehörens form varierar mellan olika modeller och områden.

CS
V závislosti na modelu nemusí být příslušenství v čárkovaném poli obsaženo. Tvar příslušenství se liší podle modelů a oblastí.

HU
A szaggatott vonallal jelölt négyzetben található tartozékok modelltől függően külön kaphatók. A tartozékok alakja modellenként és területenként eltérő.

TR
Modele bağı olarak kesik çizgi ile gösterilen kutudaki aksesuarlar dahil edilmemiş olabilir. Aksesuarların şekli modele ve bölgeye bağı olarak değişiklik gösterir.

SL
Glede na model dodatki v črtnanem okvirčku morda niso priloženi. Oblika dodatkov je odvisna od modela in območja.

VI
Tùy theo kiểu máy, các phụ kiện trong hình hộp đứt nét có thể không được bao gồm. Hình dạng các phụ kiện sẽ thay đổi tùy theo các kiểu máy và khu vực.

TH
ขึ้นอยู่กับรุ่น อาจไม่รวมอุปกรณ์เสริมมาในกล่องรูปร่างของอุปกรณ์เสริมเป็สี่เหลี่ยมตามรุ่นและพื้นที่

JA
プリンターのモデルによっては、点線内のものが同梱されていない場合があります。同梱品の形状は、プリンターのモデルやお住まいの地域によって異なります。

1

1

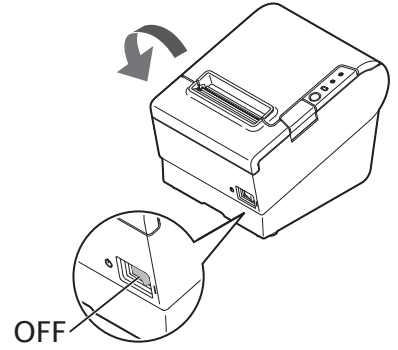

2

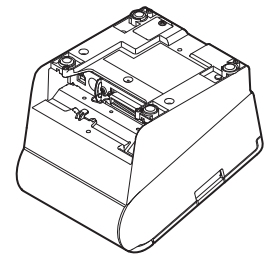

2

RS-232



1

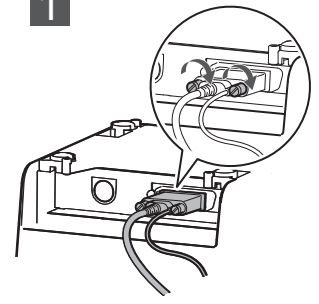

2

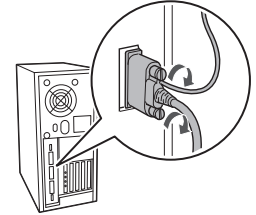

USB



1

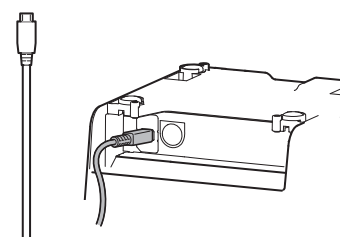

2

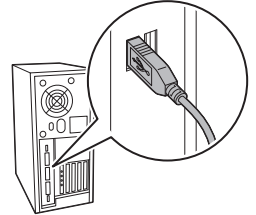

IEEE1284

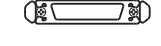

1

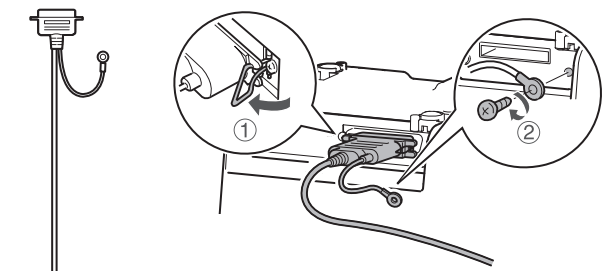

2

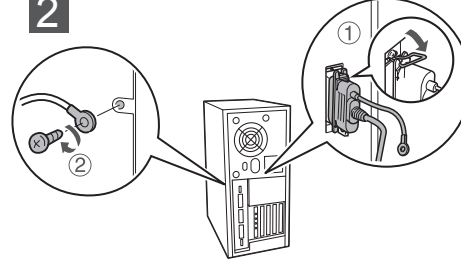

USB Plus Power



1

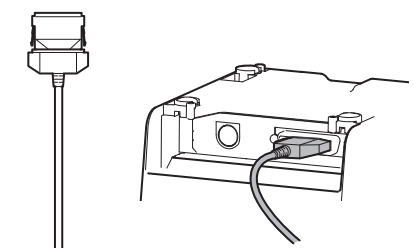

2

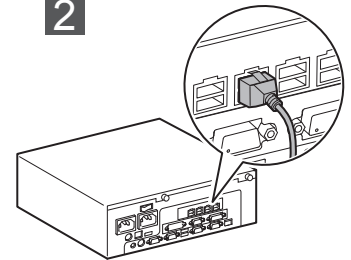

10/100BASE-TX



1

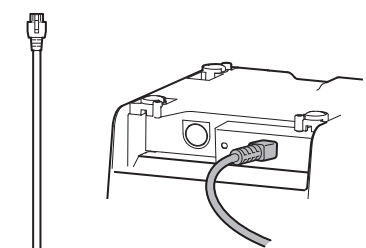

2

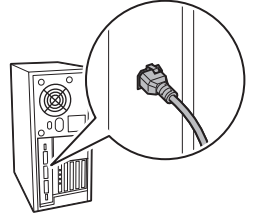

3

1

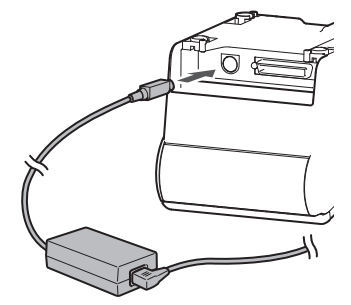

2

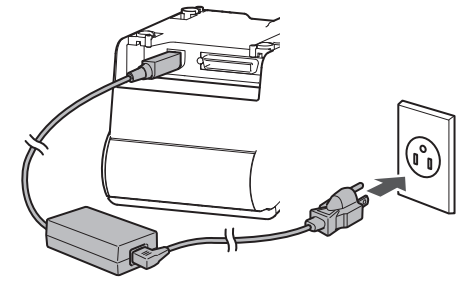

4

1

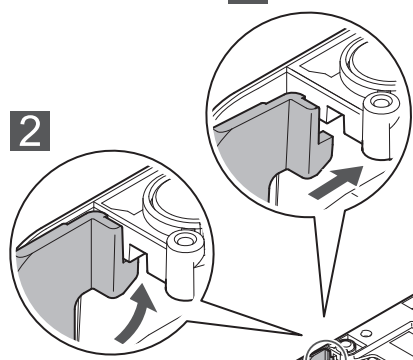

2

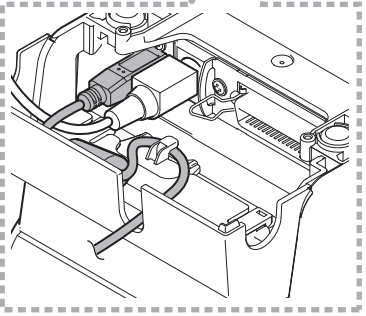
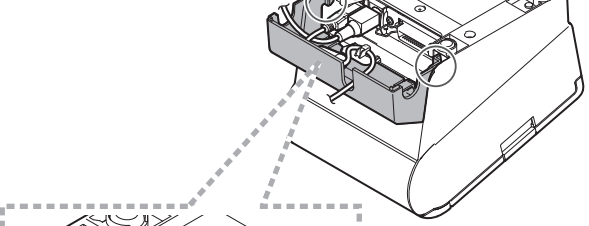
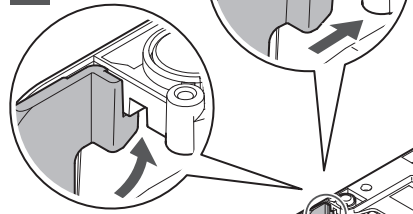

5

1

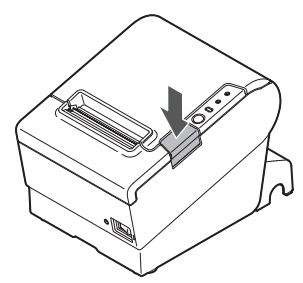

2

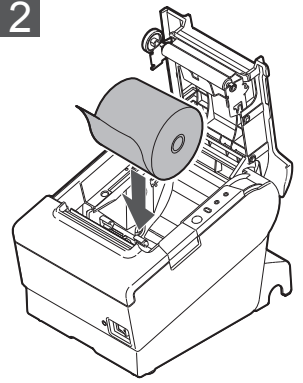

3

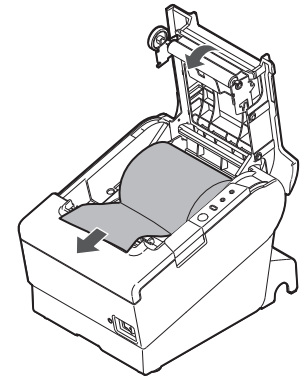

4

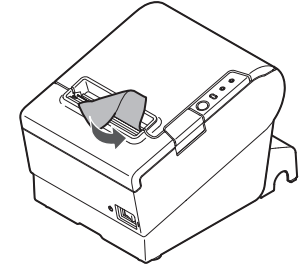

6

1

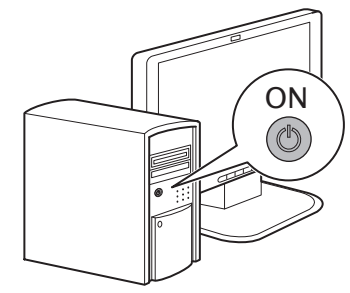

2

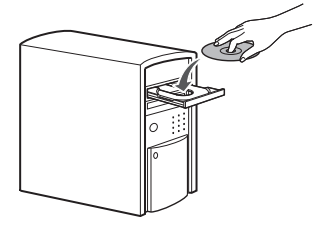

3

