

TM-T88V

Technical Reference Guide

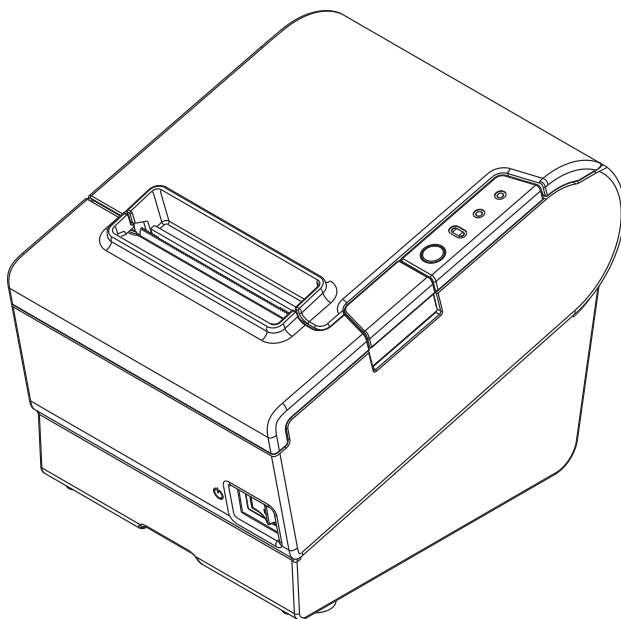

Product Overview

Describes features and general specifications for the product.

Setup

Describes setup and installation of the product and peripherals.

Application Development Information

Describes how to control the printer and necessary information when you develop applications.

Handling

Describes how to handle the product.

Replacement of the TM-T88IV

Describes precautions for replacement.

Appendix

Describes interfaces, connectors, and character code tables.

Cautions

- No part of this document may be reproduced, stored in a retrieval system, or transmitted in any form or by any means, electronic, mechanical, photocopying, recording, or otherwise, without the prior written permission of Seiko Epson Corporation.
- The contents of this document are subject to change without notice. Please contact us for the latest information.
- While every precaution has been taken in the preparation of this document, Seiko Epson Corporation assumes no responsibility for errors or omissions.
- Neither is any liability assumed for damages resulting from the use of the information contained herein.
- Neither Seiko Epson Corporation nor its affiliates shall be liable to the purchaser of this product or third parties for damages, losses, costs, or expenses incurred by the purchaser or third parties as a result of: accident, misuse, or abuse of this product or unauthorized modifications, repairs, or alterations to this product, or (excluding the U.S.) failure to strictly comply with Seiko Epson Corporation's operating and maintenance instructions.
- Seiko Epson Corporation shall not be liable against any damages or problems arising from the use of any options or any consumable products other than those designated as Original EPSON Products or EPSON Approved Products by Seiko Epson Corporation.

Trademarks

EPSON and ESC/POS are registered trademarks of Seiko Epson Corporation in Japan and other countries/regions.

Microsoft and Windows are registered trademarks of Microsoft Corporation.

ESC/POS® Command System

EPSON ESC/POS is a proprietary POS printer command system that includes patented or patent-pending commands. ESC/POS is compatible with most EPSON POS printers and displays.



ESC/POS is designed to reduce the processing load on the host computer in POS environments. It comprises a set of highly functional and efficient commands and also offers the flexibility to easily make future upgrades.

Copyright © 2010 Seiko Epson Corporation. All rights reserved.

For Safety

Key to Symbols

The symbols in this manual are identified by their level of importance, as defined below. Read the following carefully before handling the product.

 WARNING	You must follow warnings carefully to avoid serious bodily injury.
 CAUTION	Provides information that must be observed to prevent damage to the equipment or loss of data. <ul style="list-style-type: none">• Possibility of sustaining physical injuries.• Possibility of causing physical damage.• Possibility of causing information loss.
CAUTION	Provides information that must be observed to avoid damage to your equipment or a malfunction.
NOTE	Provides important information and useful tips.

Warnings



WARNING

- To avoid risk of electric shock, do not set up this product or handle cables during a thunderstorm
- **Never insert or disconnect the power plug with wet hands.**
Doing so may result in severe shock.
- **Handle the power cable with care.**
Improper handling may lead to fire or electric shock.
 - * Do not modify or attempt to repair the cable.
 - * Do not place any heavy object on top of the cable.
 - * Avoid excessive bending, twisting, and pulling.
 - * Do not place the cable near heating equipment.
 - * Check that the plug is clean before plugging it in.
 - * Be sure to push the plug all the way in.
- **Be sure to use the specified power source.**
Connection to an improper power source may cause fire or shock.
- **Do not place multiple loads on the power outlet.**
Overloading the outlet may lead to fire.
- **Shut down your equipment immediately if it produces smoke, a strange odor, or unusual noise.**
Continued use may lead to fire. Immediately unplug the equipment and contact your dealer or a Seiko Epson service center for advice.
- **Never attempt to repair this product yourself.**
Improper repair work can be dangerous.
- **Never disassemble or modify this product.**
Tampering with this product may result in injury or fire.
- **Do not allow foreign matter to fall into the equipment.**
Penetration by foreign objects may lead to fire.
- **If water or other liquid spills into this equipment, do not continue to use it.**
Continued use may lead to fire. Unplug the power cord immediately and contact your dealer or a Seiko Epson service center for advice.
- **Using in the presence of silicon gas (silicon adhesive, silicon oil, silicon powder, etc.) including siloxane and of malignant gas (nitric acid, hydrosulfuric, ammonia, chlorine, etc.) may cause contact failure at contact points in a mechanical switch and a DC motor, etc., in a short time because of adhesion or oxidization of the insulation film.**
- **If you open the DIP switch cover, be sure to close the cover and tighten the screw after adjusting the DIP switch.**
Using this product with the cover open may cause fire or electric shock.

Cautions



- **Do not connect cables in ways other than those mentioned in this manual.**
Different connections may cause equipment damage or fire.
- **Be sure to set this equipment on a firm, stable, horizontal surface.**
The product may break or cause injury if it falls.
- **Do not use this product in locations subject to high humidity or dust levels.**
Excessive humidity and dust may cause equipment damage or fire.
- **Do not place heavy objects on top of this product. Never stand or lean on this product.**
Equipment may fall or collapse, causing breakage and possible injury.
- **Take care not to injure your fingers on the manual cutter**
 - * When you remove printed paper
 - * When you perform other operations such as loading/replacing roll paper
- **Do not open the roll paper cover without taking the necessary precautions, as this can result in injury from the autocutter fixed blade.**
- **Do not use aerosol sprayers containing flammable gas inside or around this product.**
Doing so may cause fire.
- **To ensure safety, unplug this product before leaving it unused for an extended period.**

Restriction of Use

When this product is used for applications requiring high reliability/safety, such as transportation devices related to aviation, rail, marine, automotive, etc.; disaster prevention devices; various safety devices, etc.; or functional/precision devices, etc., you should use this product only after giving consideration to including fail-safes and redundancies into your design to maintain safety and total system reliability. Because this product was not intended for use in applications requiring extremely high reliability/safety, such as aerospace equipment, main communication equipment, nuclear power control equipment, or medical equipment related to direct medical care, etc., please make your own judgment on this product's suitability after a full evaluation.

About this Manual

Aim of the Manual

This manual provides developers/engineers with all the necessary information for design, development and installation of a POS system, and also design and development of a printer application.

Manual Content

The manual is made up of the following sections:

Chapter 1	Product Overview
Chapter 2	Setup
Chapter 3	Application Development Information
Chapter 4	Handling
Chapter 5	Replacement of the TM-T88IV
Appendix	Specifications of Interfaces and Connectors Character Code Tables

Contents

■ For Safety	3
Key to Symbols	3
Warnings	4
Cautions.....	5
■ Restriction of Use	5
■ About this Manual	6
Aim of the Manual.....	6
Manual Content	6

Product Overview 13

■ Features	13
■ Product Configurations	15
Interfaces	15
Buzzer	15
Colors	15
Accessories.....	16
■ Part Names and Functions	17
Power Switch	17
Power Switch Cover.....	18
Control Panel	18
Connectors.....	19
Offline	20
■ Error Status	21
Automatically Recoverable Errors	21
Recoverable Errors.....	21
Unrecoverable Errors	22
■ NV Memory (Non-Volatile Memory)	23
NV Graphics Memory.....	23
User NV Memory	23
Memory Switches (Customized Value)	24
Receipt Enhancement.....	24
User-defined Page	24
Maintenance Counter	24
■ Product Specifications	25
Printing Specifications	26
Character Specifications	27
Printable Area	28
Printing and Cutting Positions	30
Paper Specifications.....	31
Electrical Characteristics	32
Environmental Conditions.....	33
External Dimensions and Mass	34

■ Option Specifications	35
Power Supply Unit (PS-180)	35
<hr/>	
Setup	37
■ Flow of Setup.....	37
■ Installing the Printer.....	38
Important Notes on Horizontal Installation	38
Important Notes on Wall Hanging.....	38
■ Changing the Paper Width.....	39
■ Setting the DIP Switches.....	41
Setting Procedure.....	41
For Serial Interface.....	42
For Parallel Interface	44
For Built-in USB Interface	45
For Ethernet/Wireless LAN/USB Interface	46
Selecting the Print Density (DIP Switches 2-3/2-4).....	47
Selecting the BUSY Status	48
■ Connecting the Power Supply Unit (PS-180)	49
Connecting the Power Supply Unit	49
■ Setting the Memory Switches (Customized Value).....	50
Functions	51
■ Adjusting the Paper Roll Near-End Sensor	55
■ Connecting the Printer to the Host Computer	56
For Serial Interface.....	56
For Parallel Interface	58
For USB Interface.....	59
For Ethernet Interface	62
For Wireless LAN Interface	64
■ Connecting the Cash Drawer	65
Connecting the Drawer Kick-out Cable.....	65
■ Setting the Internal Buzzer (for Model with an Internal Buzzer).....	67
■ Connecting the Optional External Buzzer.....	68
Unpacking.....	68
Installation Position	69
Installation Procedures.....	70
Adjusting the Buzzer Volume	71
Setting the Optional External Buzzer	71
■ Attaching the Connector Cover	72
■ Arranging the Cables	74

Application Development Information.....75

■ How to Control the Printer.....	75
Selecting a Driver.....	75
ESC/POS Commands	76
■ Software and Manuals	81
Printer Drivers.....	81
Utilities.....	83
How to Get Drivers, Manuals, and the Utility	84
■ Setting/Checking Modes.....	85
Self-test Mode	85
Hexadecimal Dumping Mode	87
NV Graphics Print Mode	88
Receipt Enhancement Information Print Mode.....	89
Memory Switch Setting Mode.....	90

Handling91

■ Installing and Replacing Roll Paper.....	91
■ Removing Jammed Paper.....	93
■ Cleaning the Thermal Head	95
■ Preparing for Transport	96

Replacement of the TM-T88IV97

■ Compatibility	97
Printing	97
Print Density	97
Two-Color Printing	97
Number of Head Energizing Parts.....	97
Printable Area (for 80 mm Width Paper).....	98
Cutting Method	98
Manual Paper Feed	98
Receive Buffer	98
Memory Capacity	98
Electrical Characteristics	98
DIP Switches	99
Printer Status	99
Logo Registration	99
Driver Compatibility	99
USB Low Power Consumption Mode	100
Maintenance Counter	100
Buzzer	100
Power Supply Box.....	100
Overall Dimensions	101

■ Additional Functions and Functional Improvements.....	102
Paper Width	102
Print Speed	102
Barcodes	102
Number of Characters.....	103
Image Tone Setting	103
Interface	103
USB Class.....	103
Coupon Printing	103
Customized Value	104
R/E Information Printing Mode	104
Low Power Load Mode.....	105
Reliability	105

Appendix..... 107

■ Specifications of Interfaces and Connectors.....	107
RS-232 Serial Interface.....	107
IEEE 1284 Parallel Interface	110
USB (Universal Serial Bus) Interface	113
■ Character Code Tables	114
Common to All Pages.....	114
Page 0 (PC437: USA, Standard Europe).....	115
Page 1 (Katakana).....	116
Page 2 (PC850: Multilingual)	117
Page 3 (PC860: Portuguese)	118
Page 4 (PC863: Canadian-French).....	119
Page 5 (PC865: Nordic)	120
Page 11 (PC851: Greek)	121
Page 12 (PC853: Turkish).....	122
Page 13 (PC857: Turkish).....	123
Page 14 (PC737: Greek)	124
Page 15 (ISO8859-7: Greek)	125
Page 16 (WPC1252)	126
Page 17 (PC866: Cyrillic #2)	127
Page 18 (PC852: Latin2)	128
Page 19 (PC858: Euro)	129
Page 20 (KU42: Thai)	130
Page 21 (TIS11: Thai).....	131
Page 26 (TIS18: Thai).....	132
Page 30 (TCVN-3: Vientamese)	133
Page 31 (TCVN-3: Vientamese)	134
Page 32 (PC720: Arabic).....	135
Page 33 (WPC775: Baltic Rim)	136
Page 34 (PC855: Cyrillic).....	137
Page 35 (PC861: Icelandic)	138
Page 36 (PC862: Hebrew)	139
Page 37 (PC864: Arabic).....	140
Page 38 (PC869: Greek).....	141

Page 39 (ISO8859-2: Latin2)	142
Page 40 (ISO8859-15: Latin9)	143
Page 41 (PC1098: Farci)	144
Page 42 (PC1118: Lithuanian)	145
Page 43 (PC1119: Lithuanian)	146
Page 44 (PC1125: Ukranian)	147
Page 45 (WPC1250: Latin 2)	148
Page 46 (WPC1251: Cyrillic)	149
Page 47 (WPC1253: Greek)	150
Page 48 (WPC1254: Turkish)	151
Page 49 (WPC1255: Hebrew)	152
Page 50 (WPC1256: Arabic)	153
Page 51 (WPC1257: Baltic Rim)	154
Page 52 (WPC1258: Vientamese)	155
Page 53 (KZ1048: Kazakhstan)	156
Page 255 (User-Defined Page)	157
International Character Sets	158



Product Overview

This chapter describes features and specifications of the product.

Features

Printing

- High speed printing (300 mm/s maximum).
- Shifting from 80 mm width paper printing to 58 mm width paper printing is available.
- Multi-tone graphic printing.
- Coupon print function is supported.

Handling

- Easy drop-in paper loading

Software

- Command protocol is based on the ESC/POS Proprietary Command System.
- OPOS ADK, OPOS ADK for .NET, JavaPOS ADK, and Windows printer drivers are available.
- In addition to supporting several kinds of bar code printing, DS1 DataBar printing and two-dimensional symbol (PDF417, QR code, MaxiCode, Composite Symbology) printing are possible.
- Various layouts are possible by using page mode.
- A maintenance counter function is supported.
- User-defined font function is supported.
- Paper-saving function is supported.
- Image tone can be changed.
- The remote configuration tool allows you to check the status of and configure the printer connected to a computer on the network.
- The TM-T88V is ENERGY STAR qualified. (Some configurations may be exempted, depending on their components.)

Others

- Various interface boards (EPSON UB series^{*}) can be used.
- Built-in USB interface is also available for all interface models.
- The TM-T88V Software & Documents Disc (drivers, utility, and manuals).

* Except the following interface boards with the buzzer function

* UB-E02A, UB-R02A, UB-R03A

Product Configurations

Interfaces

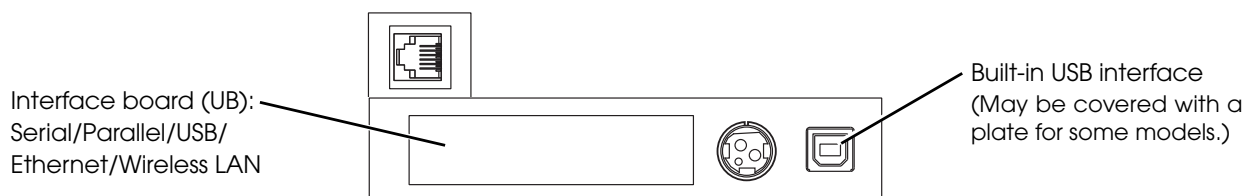

- Serial UB + built-in USB interface model
- Parallel UB + built-in USB interface model
- USB UB
- Ethernet UB
- Wireless LAN UB



CAUTION

For this printer, never use a LAN interface board or a wireless LAN interface board with a buzzer function.

Otherwise, the printer or the interface board may be damaged.

The name of interface boards with a buzzer function has "A" at the end.

Example) UB-E**A, UB-R**A (*: alphanumeric character)

Buzzer

- Model with the internal buzzer function
- Optional external buzzer

CAUTION

The optional external buzzer and the internal buzzer cannot be used together at the same time.

Colors

- ECW (Epson Cool White)
- EDG (Epson Dark Gray)

Accessories

Included

- Roll paper (for operation check)
- Power switch cover
- Connector cover
- Roll paper guide for 58 mm width paper*
- Two strips for the roll paper guide*
- Screw for the roll paper guide*
- The TM-T88V Software & Documents Disc (drivers, utilities, and documentation) *
- Warranty certificate*
- Setup Guide or User's manual

* May not be included depending on the model.

Options

- AC adapter
- AC cable
- Power supply box (Model: OT-BX88V)
- Affixing tape for fixing the printer (Model: DF-10)
- Wall hanging bracket (Model: WH-10)
- Interface boards (UB series)
- Optional external buzzer (Model: OT-BZ20)

Part Names and Functions

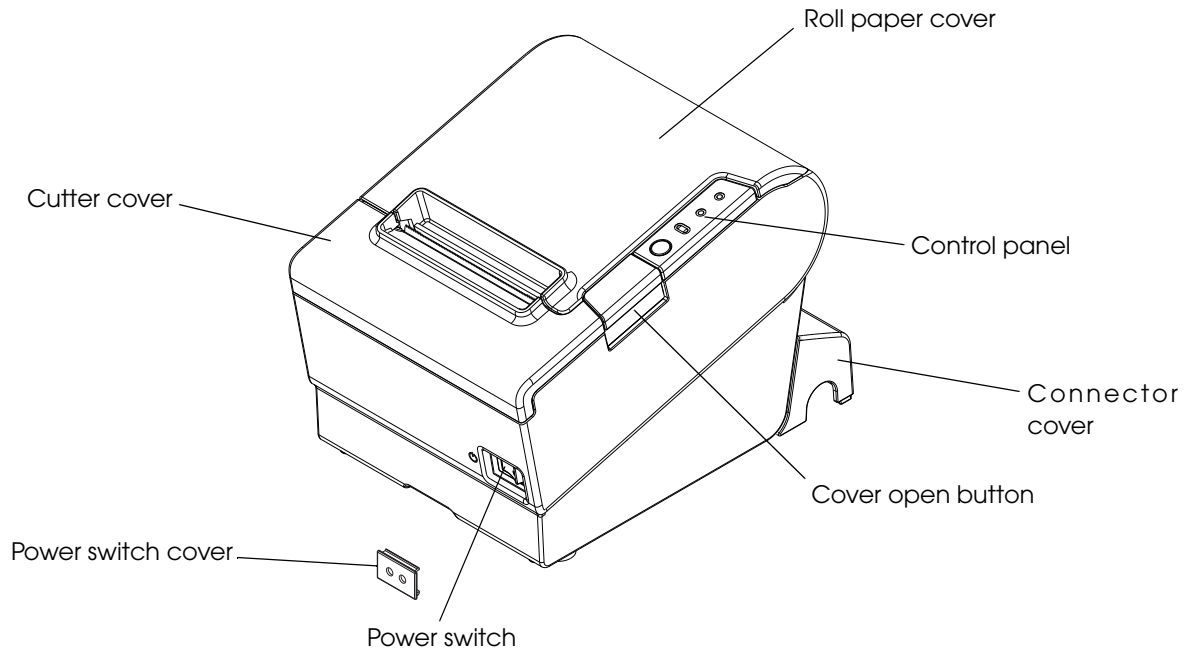

Power Switch

Turns the printer on or off. The marks on the switch: ( : OFF/ | : ON)



Before turning on the printer, be sure to check that the AC adapter is connected to the power supply.

CAUTION

Before turning the printer off, it is recommended to send a power-off command to the printer. If you use the power-off sequence, the latest maintenance counter values are saved. (Maintenance counter values are usually saved every two minutes.)

For detailed information about ESC/POS commands, see the ESC/POS Application Programming Guide.

Power Switch Cover

Install the power switch cover that comes with the TM-T88V onto the printer to prevent inadvertent changing of the power switch, to prevent tampering, and to improve the appearance of the printer.

To reset the printer when the power switch cover is installed, insert a long, thin object (such as the end of a paper clip) into the hole in the power switch cover and press the power switch.



If an accident occurs with the power switch cover attached, unplug the power cord immediately.

Continued use of the printer may cause fire or shock.

Control Panel

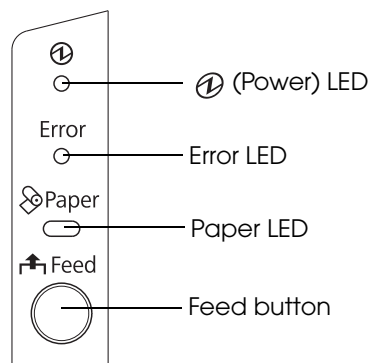

LEDs

Power LED (green)

- Lights when the power supply is on.
- Goes out when the power supply is turned off.

Error LED

Lights or flashes when the printer is offline.

- Lights after the power is turned on or after a reset (offline). Automatically goes out after a while to indicate that the printer is ready.
- Lights when the end of the roll paper is detected, and when printing has stopped (offline). If this happens, replace the roll paper.
- Flashes when an error occurs. (For details about the flash codes, see ["Error Status" on page 21.](#))
- Goes out during regular operation (online).

Paper LED

- Lights when there is no more roll paper or there is little remaining.
- Off when there is a sufficient amount of roll paper remaining.
- Flashes when a self-test is in progress.

Feed button

Pressing this button once feeds the roll paper by one line. Holding this button down feeds the roll paper continuously.

Connectors

All cables are connected to the connector panel on the lower rear of the printer.

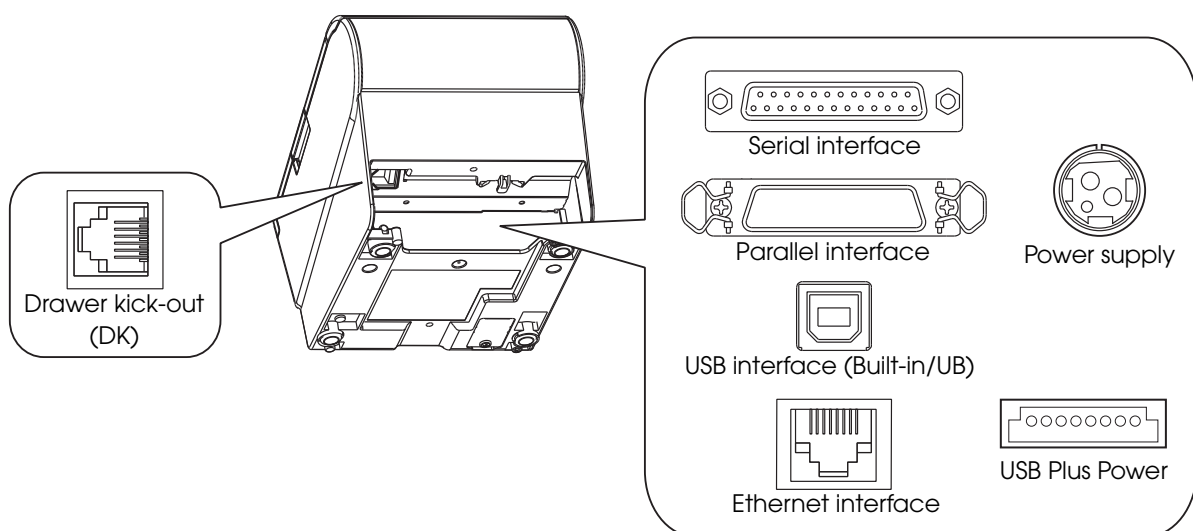

- Drawer kick-out connector: Connects a cash drawer or the optional external buzzer.
- Interface connector: Connects the printer with the host computer interface.
- Power supply connector: Connects the power supply unit

CAUTION

The picture above shows a serial interface model. For details on the various interfaces and how to connect the power supply connector and cash drawer, see ["Connecting the Printer to the Host Computer" on page 56](#) and ["Connecting the Cash Drawer" on page 65](#).

Offline

The printer automatically goes offline under the following conditions:



- During power on (including resetting with the interface) until the printer is ready
- During the self-test
- While roll paper is fed using the Feed button.
- When the cover is open.
- When the printer stops printing due to a paper-end (if an empty paper supply is detected by the roll paper end sensor or if the driver has been set to stop printing when a roll paper near-end is detected)
- When an error has occurred

Error Status

There are three possible error types: automatically recoverable errors, recoverable errors, and unrecoverable errors.



Automatically Recoverable Errors

Printing is no longer possible when automatically recoverable errors occur. They can be recovered easily, as described below.

Error	Error description	Error LED flash code 	Recovery measure
Roll paper cover open error	The roll paper cover was opened during printing.		Recovers automatically when the roll paper cover is closed.
Print head temperature error	A high temperature outside the head drive operating range was detected.		Recovers automatically when the print head cools.

Recoverable Errors

Printing is no longer possible when recoverable errors occur. They can be recovered easily by turning the power on again or sending an error recovery command from the driver after eliminating the cause of the error.

Error	Error description	Error LED flash code 	Recovery measure
Autocutter error	Autocutter does not work correctly.		Remove the jammed paper or foreign matter in the printer, close the roll paper cover, send the error recovery command, or turn the power on to recover.







CAUTION

The error recovery command is valid only if a recoverable error (excluding automatically recoverable errors) occurs.

Unrecoverable Errors

Printing is no longer possible when unrecoverable errors occur. The printer must be repaired.

 CAUTION	Turn off the power immediately when unrecoverable errors occur.
---	--

Error	Error description	Error LED flash code  Approx. 160 ms
Memory R/W error	After R/W checking, the printer does not work correctly.	
High voltage error	The power supply voltage is extremely high.	
Low voltage error	The power supply voltage is extremely low.	
CPU execution error	The CPU is executing an incorrect address.	
Internal circuit connection error	Internal circuits are not connected correctly.	

NV Memory (Non-Volatile Memory)

The printer's NV memory stores data even after the printer power is turned off. NV memory contains the following memory areas for the user:

- NV graphics memory
- User NV memory
- Memory switches (customized value)
- User-defined page
- Maintenance counter



NV memory can be rewritten about 100,000 times. As a guide, NV memory rewriting should be 10 times or less a day when you program applications.



See the ESC/POS Application Programming Guide for more details.

NV Graphics Memory

Graphics, such as shop logos to be printed on receipts, can be stored. Even with a serial interface model whose communication speed is low, high speed graphics printing is possible.

Use the TM-T88V Utility to register graphics.

You can also print and confirm the registered graphics in the NV graphics memory print mode.



- For detailed information about the TM-T88V Utility, see the TM-T88V Utility User's Manual.
- For information about how to use the NV graphics memory print mode, see ["NV Graphics Print Mode" on page 88](#).

User NV Memory

You can store and read text data for multiple purposes, such as for storing a note including customizing or maintenance information of the printer.

Memory Switches (Customized Value)

With the memory switches (customized value), which are software switches for the printer, you can set paper width, print density, font, USB class, interface mode, power supply unit capacity, automatic paper cut, paper reduction, serial interface transmission speed, and printer model. See ["Setting the Memory Switches \(Customized Value\)" on page 50](#).

Receipt Enhancement

Graphics, such as shop logos to be printed on top or bottom of receipts can be registered. Use the TM-T88V Utility to register graphics.

NOTE

For detailed information about the TM-T88V Utility, see the TM-T88V Utility User's Manual.

User-defined Page

You can store character data in the user-defined page (character code table: page 255) so that you can also print characters not resident in the printer.

Maintenance Counter

With this function, printer information, such as the number of lines printed, the number of autocuts, and printer operation time after the printer starts working, is automatically stored in NV memory. You can read the information with the Status API of the APD or OPOS ADK to use it for periodical checks or part replacement.

NOTE

Maintenance Counter can be checked with the TM-T88V Utility or in a self-test.

Product Specifications

Printing method		Thermal line printing
Cutting method		Partial cut (cutting with one point in left edge left uncut)
Roll paper (single-ply) width		80 mm width paper printing: 79.5 ± 0.5 mm (3.13 ± 0.02") 58 mm width paper printing: 57.5 ± 0.5 mm (2.26 ± 0.02")
Interfaces		Serial (RS-232), Parallel (IEEE1284), Ethernet (10/100BASE-T), USB (Full-speed), Wireless LAN (IEEE802.11b)
Buffers	Receive buffer	4 KB/45 bytes (selectable using DIP switch 1-2)
	Downloaded buffer	12 KB (both for user-defined characters and downloaded images)
	NV graphics data	256 KB
Barcode/two-dimensional symbol/ composite symbol printing		UPC-A, UPC-E, JAN 8 (EAN 8), JAN 13 (EAN 13), CODE 39, ITF, CODABAR (NW-7), CODE 93, CODE 128, GS1-128, GS1 DataBar Omnidirectional, GS1 DataBar Truncated, GS1 DataBar Stacked, GS1 DataBar Stacked Omnidirectional, GS1 DataBar Limited, GS1 DataBar Expanded, GS1 DataBar Expanded Stacked, PDF417, QR CODE, MaxiCode, Composite Symbology
DKD function		2 drives
Supplied voltage		DC 24 V ± 7%
Life	Mechanism	20,000,000 lines
	Thermal head	150 million pulses 150 km
	Autocutter	2,000,000 cuts (when using the specified original paper types, PD150R or PD160R) 1,500,000 cuts (when using paper types other than the specified original paper types)
	MTBF	360,000 hours
	MCBF	70,000,000 lines
Temperature/humidity		Operating: 5 to 45°C {41 to 113°F}, 10 to 90% RH Storage: -10 to 50°C {14 to 122°F}, 10 to 90% RH
Overall dimensions		145 × 195 × 148 mm {5.71 × 7.68 × 5.83"} (W × D × H)
Weight (mass)		Approx. 1.6 kg {3.5 lb} (roll paper excluded)

Printing Specifications

Printing method	Thermal line printing
Dot density	180 × 180 dpi
Printing direction	Unidirectional with friction feed (Reverse feed is not supported.)
Printing width	80 mm width paper printing: 72.0 mm (2.83"), 512 dots 58 mm width paper printing: 50.8 mm (2.0"), 360 dots
Characters per line	Font A (12 × 24)
	Font B (9 × 17)
	80 mm width paper printing: 42 58 mm width paper printing: 30
	80 mm width paper printing: 56 58 mm width paper printing: 40
Maximum print speed* ¹	300 mm/s
Line spacing	4.23 mm {1/6"} (factory setting, programmable by command)

dpi: dots per inch

*1: when the printer prints text (built-in fonts) with the default print density level at 24V and 25°C {77°F}.

NOTE

Printing speed may be slower, depending on the such items as the data transmission speed.

Character Specifications

Number of characters		Alphanumeric characters: 95 Extended graphics: 128 × 43 pages (including user-defined page) International characters: 18 sets GB18030-2000: 28,533 (for Simplified Chinese characters model) Big 5: 13,535 (for Traditional Chinese characters model) Korean Kanji (KC C5601): 8,366 (for Korean model) Thai character: 3-pass printing font (for South Asia model) 128 characters × 3 pages (133 character types) Vietnam character (for South Asia model) 128 characters × 2 pages (135 character types)
Character structure		Font A (default): 12 × 24 (including 2-dot horizontal spacing) Font B: 9 × 17 (including 2-dot horizontal spacing)
Character size	Font A	Standard: 1.41 × 3.39 mm Double-height: 1.41 × 6.77 mm Double-width: 2.82 × 3.39 mm Double-width, double-height: 2.82 × 6.77 mm
	Font B	Standard: 0.99 × 2.40 mm Double-height: 0.99 × 4.80 mm Double-width: 1.98 × 2.40 mm Double-width, double-height: 1.98 × 4.80 mm

Note:

1. Space between characters is not included.
2. Characters can be scaled up to 64 times as large as the standard size.

Printable Area

80 mm paper width printing

The printable area of paper with a width of 79.5 ± 0.5 mm { 3.13 ± 0.02 "} is 72.2 ± 0.2 mm { 2.84 ± 0.008 "} (512 dots), and the space on the right and left sides is approximately 3.7 mm {0.15"}.

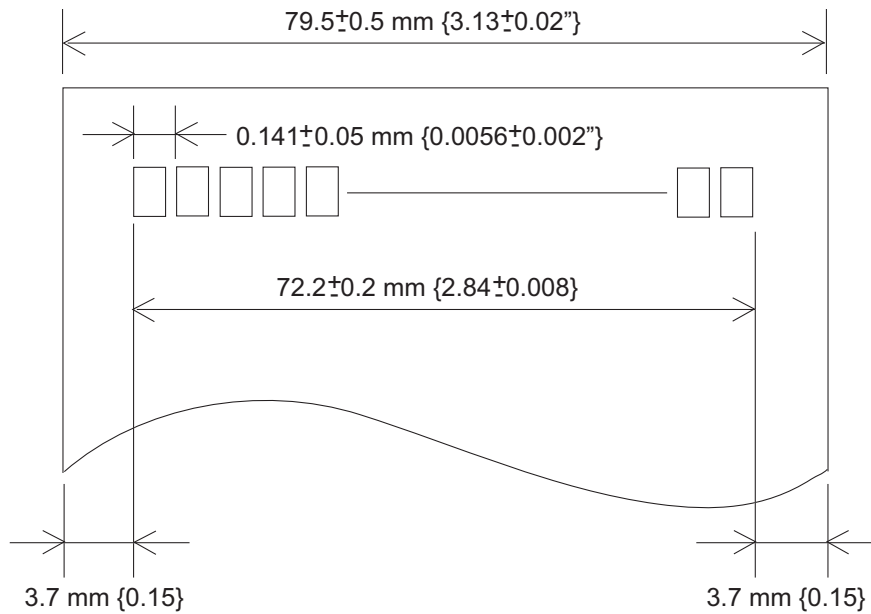

All the numeric values are typical.

CAUTION

- In 2-divided energizing, the print position within the printable area of the thermal elements for dots 1 to 256 and 257 to 512 is shifted approximately 0.07 mm {0.0028"} in the paper feed direction as shown in the figure below.



- In 4-divided energizing, the print position within the printable area of the thermal elements for dots 1 to 128, 129 to 256, 257 to 384, and 385 to 512 is shifted approximately 0.04 mm {0.0016"} in the paper feed direction as shown in the figure below.

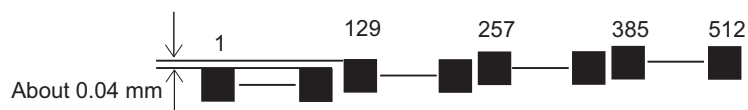

58 mm paper width printing

The printable area of paper with a width of 57.5 ± 0.5 mm $\{2.26 \pm 0.02\}$ " is 50.8 ± 0.2 mm $\{2.00 \pm 0.008\}$ " (360 dots), and the space on the left side is approximately 3.7 mm $\{0.15\}$ " and the space on the right side is approximately 3.0 mm $\{0.12\}$ ".

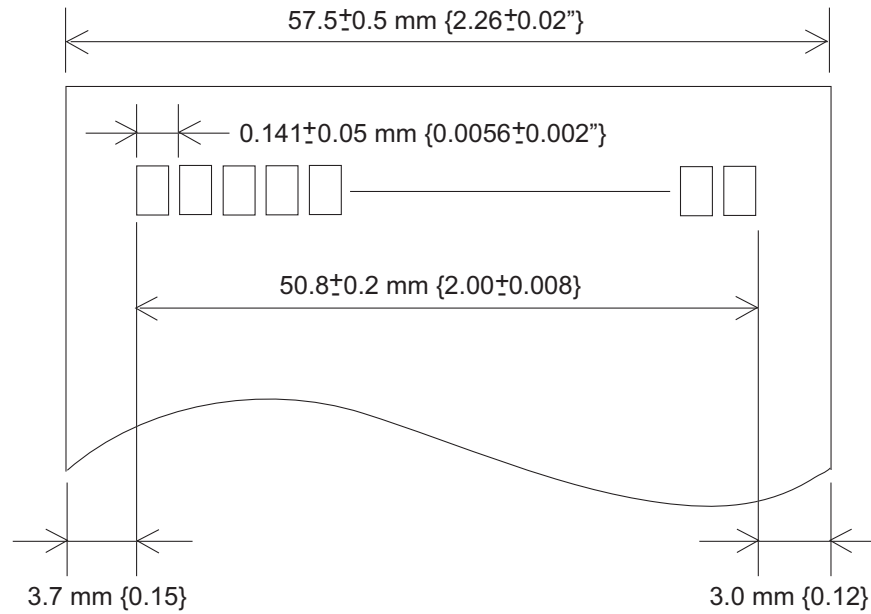

All the numeric values are typical.

CAUTION

- In 2-divided energizing, the print position within the printable area of the thermal elements for dots 1 to 256 and 257 to 360 is shifted approximately 0.07 mm $\{0.0028\}$ " in the paper feed direction as shown in the figure below.



- In 4-divided energizing, the print position within the printable area of the thermal elements for dots 1 to 128, 129 to 256, and 257 to 360 is shifted approximately 0.04 mm $\{0.0016\}$ " in the paper feed direction as shown in the figure below.



Printing and Cutting Positions

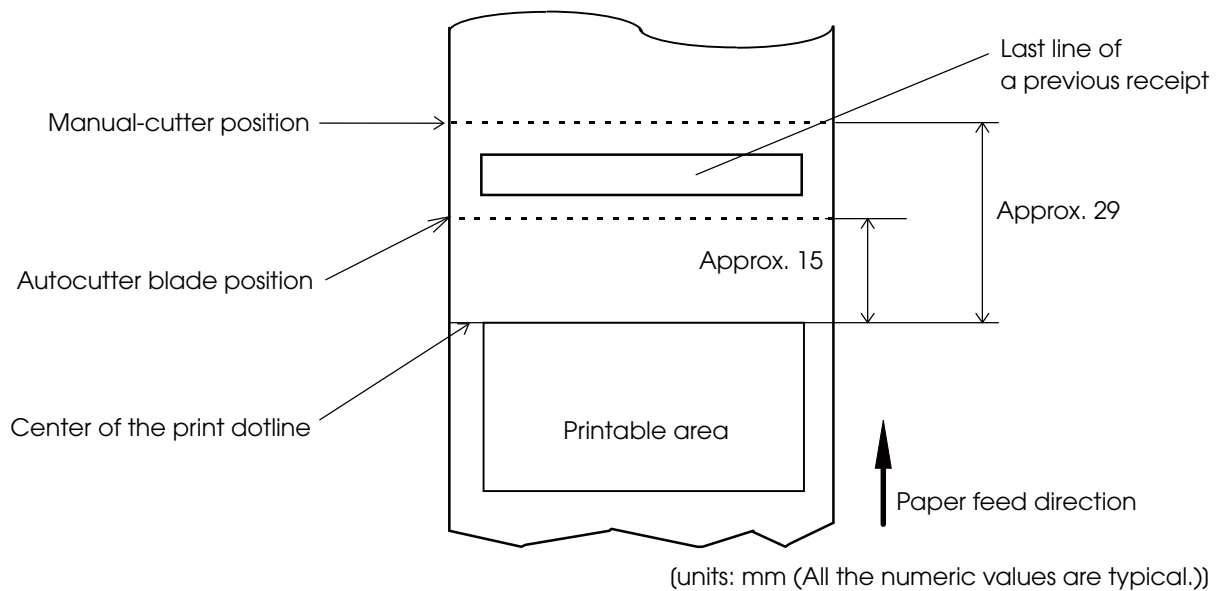

CAUTION

The values above may vary slightly as a result of paper slack or variations in the paper. Take this into account when setting the cutting position of the autocutter.

Paper Specifications

Paper types	Specified thermal paper	
Form	Roll paper	
Size	Roll paper diameter	83 mm {3.27"} maximum
	Roll paper spool	Inside: 12 mm {0.47"}, Outside: 18 mm {0.71"}
	Roll width when taken up	80 mm width paper printing: 80 + 0.5/-1.0 mm 58 mm width paper printing: 58 + 0.5/-1.0 mm
	Paper width	80 mm width paper printing: 79.5 ± 0.5 mm 58 mm width paper printing: 57.5 ± 0.5 mm
Specified roll paper type	NTP080-80/NTP058-80 In U.S.A.: Nakagawa Mfg. (USA) Inc. In Europe: Nakagawa Mfg. (Europe) GmbH In Southeast Asia: N.A.K. Mfg. (Malaysia) SDN BHD (Original paper: TF50KS-E Nippon Paper Industries Co., Ltd.)	
Specified original paper type	TF50KS-E, TF60KS-E (NIPPON Paper Industries Co., Ltd.) PD150R, PD160R, PD190R (OJI Paper Mfg. Co., Ltd.) P220AGB-1 (Mitsubishi Paper Mills Limited.) P300, P310, P350 (Kanzaki Specialty Papers) AF50KS-E (Jujo Thermal Oy) F5041 (Mitsubishi HiTec Paper Flensburg GmbH) KT55F20, KT48F20 (Koehler Paper Group)	

CAUTION

- Paper must not be pasted to the roll paper spool.
- The remaining amount of the roll paper when a roll paper near-end is detected differs depending on the spool type.

Electrical Characteristics

Supply voltage		DC 24V ± 7%
Current consumption (at 24V, 25°C, normal print density)	Standby	Mean: Approximately 0.015A Maximum 1A for drawer kick-out driving.
	Operating	Mean: Approximately 1.8A Note: When print ratio is approximately 18% <ul style="list-style-type: none"> • Continuous printing for 50 lines (repeating 20H-7FH) <ul style="list-style-type: none"> * Font A * 42 columns * ASCII character • 5 line feeding • Autocutting

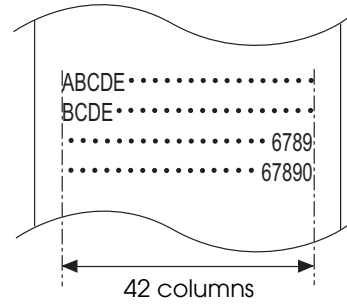

Environmental Conditions

Temperature/ Humidity	Operating	5 to 45°C {41 to 113°F}, 10 to 90% RH (See the operating temperature and humidity range below.)
	Storage (Factory packing)	-10 to 50°C {14 to 122°F}, 10 to 90% RH (except for paper)
		<p>Relative humidity (%RH)</p> <p>Ambient temperature (°C)</p> <p>Operating environment range</p> <p>31°C, 90%</p> <p>34°C, 90%</p> <p>34°C, 75%</p> <p>40°C, 65%</p> <p>45°C, 50%</p> <p>45°C, 43%</p> <p>— Specified original paper other than below</p> <p>— Specified original paper: P300, P310, P350</p>
Acoustic noise (operating)		<p>Approximately 55 dB (bystander position)</p> <p>Note:</p> <p>The values above are measured in the Epson evaluation condition.</p> <p>Acoustic noise differs depending on the paper used, printing contents, and the setting values, such as print speed or print density.</p>

External Dimensions and Mass

- Width: Approximately 145 mm {5.71"}
- Depth: Approximately 195 mm {7.68"}
- Height: Approximately 148 mm {5.83"}
- Mass: Approximately 1.6 kg {3.53 lb} (except for roll paper)

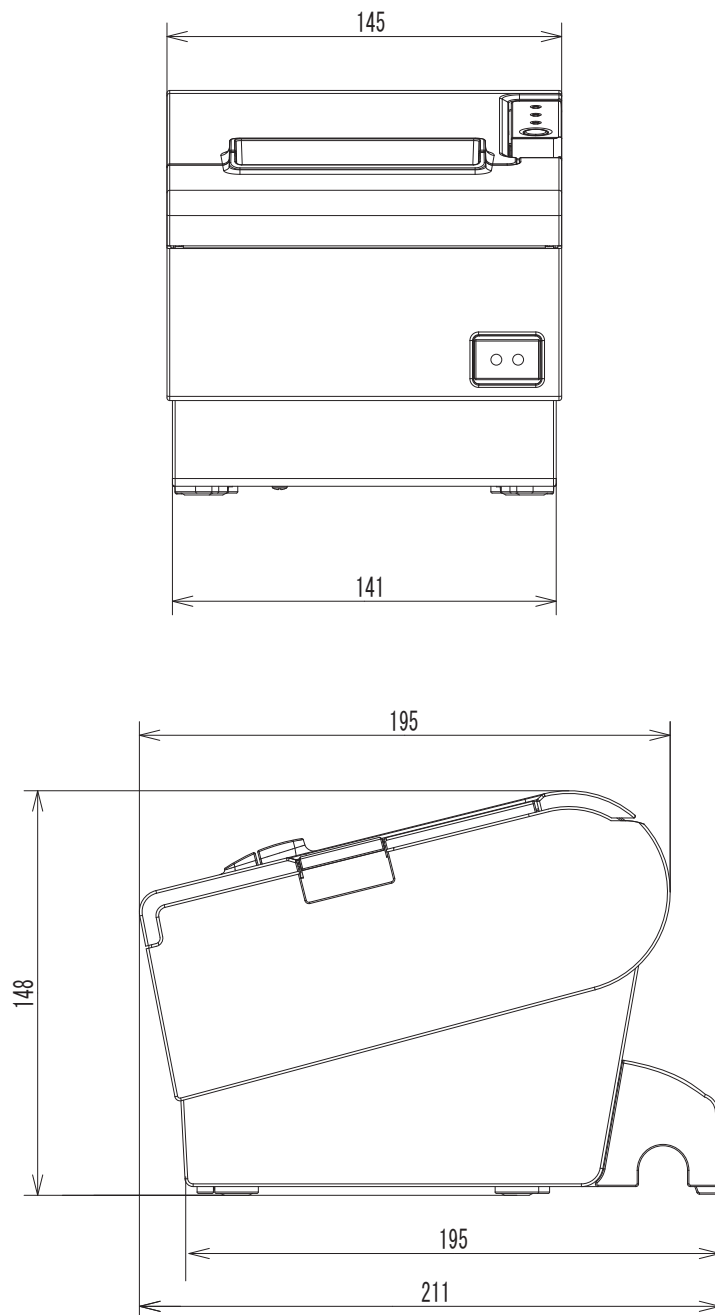

(Units: mm)

Option Specifications

Power Supply Unit (PS-180)

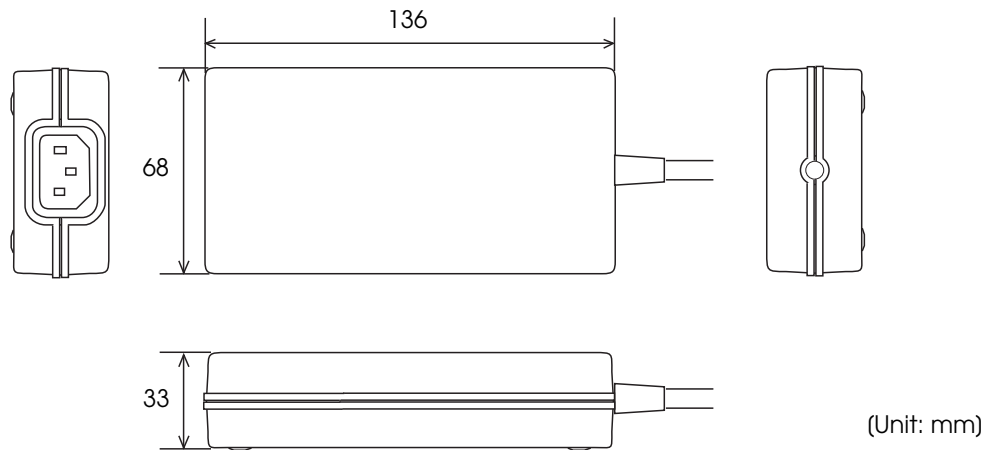

Electric characteristics	Input conditions	Input voltage (rating): 90 to 264VAC (100VAC -10% to 230VAC +15%)
		Frequency (rating): 50/60 Hz \pm 3 Hz
		Input current (rating): 1.3A
	Output conditions	Output voltage (rating): 24VDC \pm 5%
		Output current (rating): 2.1A
Case specifications	Dimensions (W x D x H)	136 x 33 x 68 mm {5.35 x 1.30 x 2.68"} (excluding projections)
	Weight	Approx. 0.4 kg {14.11 oz} (excluding the AC cable)
	Color	Black (matte)

CAUTION

For Energy Star printers, always use the power supply that came with your printer.

NOTE

For detailed information about the PS-180, see the instruction manual for the PS-180.



Setup

This chapter describes setup and installation of the product and peripherals.

Flow of Setup

This chapter consists of the following sections along with the setup flow of the product and peripherals.

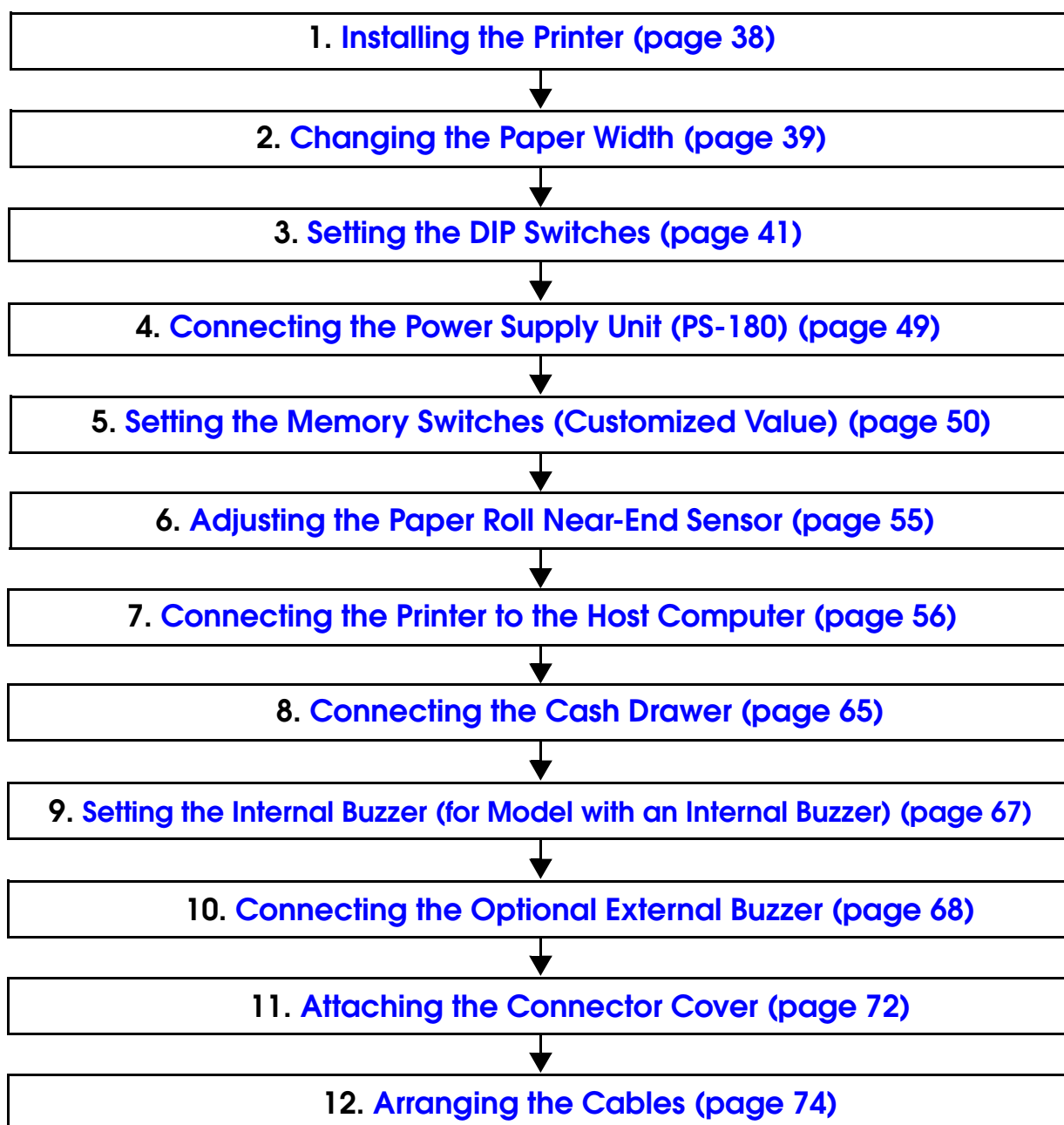

Installing the Printer

You can install this printer horizontally. With an optional hanging bracket (WH-10), you can also attach the printer to a wall.

Important Notes on Horizontal Installation

- The printer must be installed horizontally on a flat surface (not tilted).
- Do not place the printer in dusty locations.
- Do not knock or strike the printer. This may cause defective print.
- Do not catch cables or place foreign matter under the printer.

Important Notes on Wall Hanging

You need to perform the following tasks to install the printer on a wall. For more details, see the installation manual for the optional wall hanging bracket (WH-10).

- Installing the roll-paper stoppers
- Changing the location of the roll paper near-end sensor
- Attaching the connector cover
- Attaching the wall hanging bracket (WH-10)

For the other notes, see the installation manual for the optional wall hanging bracket (WH-10).

CAUTION

Be sure to attach the connector cover when you install the printer on a wall using the wall hanging bracket.

Changing the Paper Width

The printer is initially set to print on 80 mm width paper and you can change the printer to print on 58 mm width paper by installing the roll paper guide and changing the paper width setting with the customized value.

Follow the steps below to install the roll paper guide.

CAUTION

Once you change the paper width from 80 mm to 58 mm, you cannot change it back to 80 mm.

NOTE

To set the customized value, see "[Setting the Memory Switches \(Customized Value\)](#)" on [page 50](#).

- 1 Open the roll paper cover.
- 2 Install the roll paper guide so that the projection on its bottom is aligned with the hole at the right of the roll paper holder.

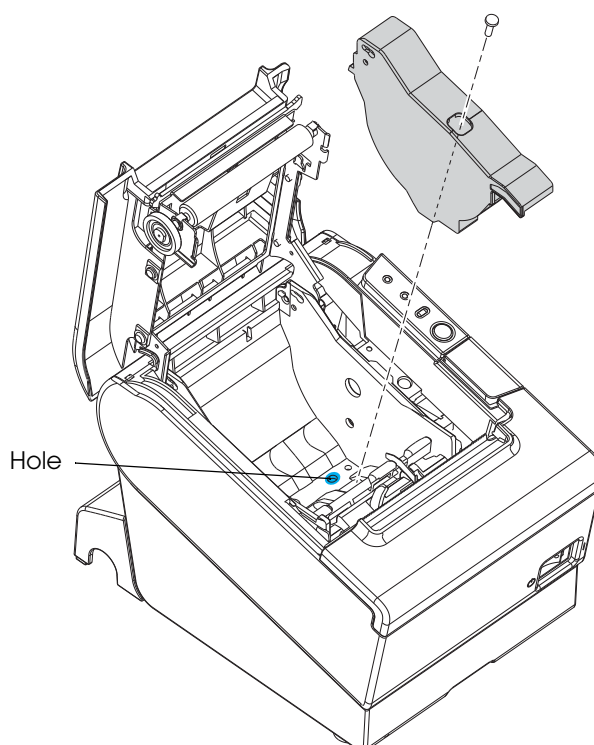

- 3 Tighten the enclosed screw to fix the roll paper guide.

- 4** Paste the enclosed 2 small strips along the roll paper guide on the bottom of the roll paper holder.

CAUTION

Make sure the space between the top edge of the strip and the line of the groove in the roll paper guide is 0.5 mm or less.

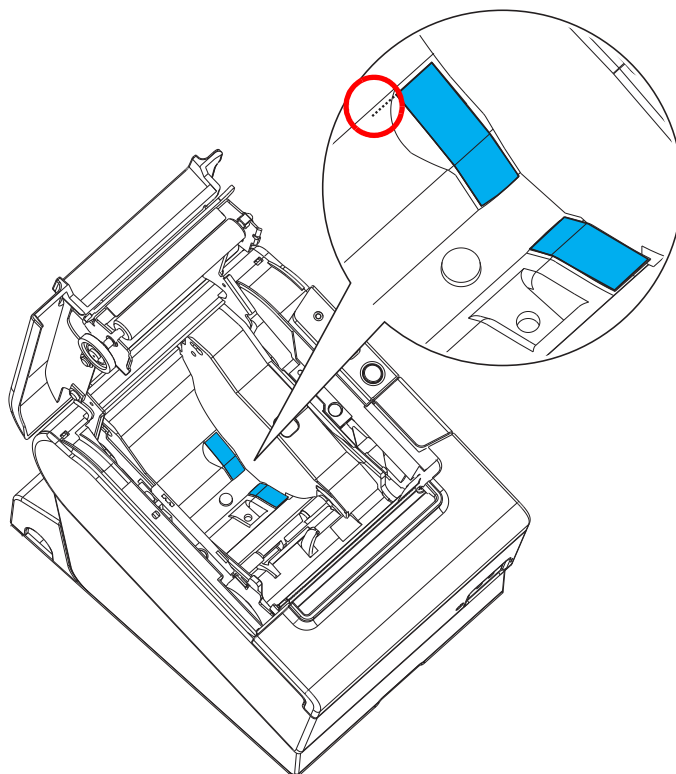

Setting the DIP Switches

On this printer, you can make various settings with DIP switches.

The DIP switches are already set for the current interfaces. Change the setting if necessary. Functions of the DIP switches differ depending on the interface.

NOTE

For models with the buzzer function, see also ["Setting the Internal Buzzer \(for Model with an Internal Buzzer\)"](#) on page 67.

Setting Procedure

Follow the steps below to change the DIP switch settings.



Before you remove the DIP switch cover, turn the printer off.
Otherwise, a short-circuit may cause the printer to malfunction.

CAUTION

DIP switch settings are enabled only when the power is turned on or the printer is reset via the interface. If the settings are changed after that, the functions will not change.

- 1 Make sure the power supply for the printer is turned off.
- 2 Unscrew the screw to remove the DIP switch cover from the base of the printer.

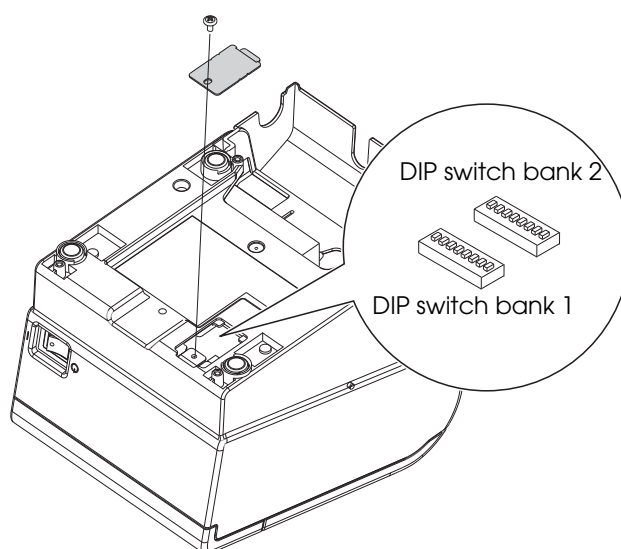

- 3 Set the DIP switches, using the tip of a tool, such as a small screwdriver.
- 4 Replace the DIP switch cover, and screw it in place.

For Serial Interface

When using the built-in USB interface, it is not necessary to change the DIP switch setting but their function changes. For the details, see ["For Built-in USB Interface" on page 45.](#)

DIP Switch Bank 1

SW	Function	ON	OFF	Initial setting
1-1	Data reception error	Ignored	Prints "?"	OFF
1-2	Receive buffer capacity	45 bytes	4 KB	OFF
1-3	Handshaking	XON/XOFF	DTR/DSR	OFF
1-4	Word length	7 bits	8 bits	OFF
1-5	Parity check	Yes	No	OFF
1-6	Parity selection	Even	Odd	OFF
1-7	Transmission speed selections	See the "Transmission Speed (DIP Switches 1-7/1-8)" table below.		ON
1-8				OFF

CAUTION

For DIP switch 1-2 (Receive buffer capacity), see also DIP switch 2-5 (Sets the release condition of the receive buffer BUSY state.)

Transmission Speed (DIP Switches 1-7/1-8)

Transmission speed (bps: bits per second)	SW 1-7	SW 1-8
38400	ON	ON
2400, 4800, 9600, 19200, 38400, 57600, 115200*		
4800	OFF	ON
9600 (default)	ON	OFF
19200	OFF	OFF

bps: bits per second

* When DIP switches 1-7 and 1-8 are set to ON, the value (initially 38400) can be set to any of the values listed in the lower portion of the row using a command, memory switch setting mode, or TM-T88V Utility. (See ["Setting the Memory Switches \(Customized Value\)" on page 50.](#))

NOTE

Depending on print conditions, such as print duty, print head temperature, and data transmission speed, print speed is automatically adjusted, which can cause white lines due to intermittent print (the motor sometimes stops). To avoid this, set the transmission speed higher or keep the print speed constant by setting it lower.

DIP Switch Bank 2

SW	Function	ON	OFF	Initial setting
2-1	Handshaking (BUSY condition)	Receive buffer full	<ul style="list-style-type: none"> • Offline • Receive buffer full 	OFF
2-2	Reserved (Do not change setting)	Fixed to OFF		OFF
2-3 ~ 2-4	Selects print density	See "Selecting the Print Density (DIP Switches 2-3/2-4)" on page 47.		OFF
2-5	Sets the release condition of the receive buffer BUSY state. (This function is effective when DIP Switch 1-2 is set to off.)	Releases the BUSY state when the remaining capacity of the receive buffer reaches 138 bytes.	Releases the BUSY state when the remaining capacity of the receive buffer reaches 256 bytes.	OFF
2-6	Reserved (Do not change setting)	Fixed to OFF		OFF
2-7	I/F pin 6 reset signal	Enabled	Disabled	OFF
2-8	IF pin 25 reset signal	Enabled	Disabled	OFF

CAUTION

- For DIP Switch 2-1 (BUSY condition), see also ["Selecting the BUSY Status"](#) on page 48.
- When you use the APD, change the setting of DIP switch 2-1 (BUSY condition) to ON.
- Do not change the setting of DIP switches 2-2 and 2-6. Otherwise, the printer may not operate normally.

For Parallel Interface

When using the built-in USB interface, it is not necessary to change the DIP switch setting but their function changes. For the details, see ["For Built-in USB Interface" on page 45](#).

DIP Switch Bank 1

SW	Function	ON	OFF	Initial setting
1-1	Auto line feed	Always enabled	Always disabled	OFF
1-2	Receive buffer capacity	45 bytes	4 KB	OFF
1-3	Selects paper sensors to output paper-end signals (default value of a command)	Disabled	Roll paper end sensor enabled, roll paper near-end sensor enabled	OFF
1-4	Error signal output	Disabled	Enabled	OFF
1-5 ~ 1-8	Undefined	—		OFF

DIP Switch Bank 2

SW	Function	ON	OFF	Initial setting
2-1	Handshaking (BUSY condition)	Receive buffer full	<ul style="list-style-type: none"> Offline Receive buffer full 	OFF
2-2	Reserved (Do not change setting)	Fixed to OFF		OFF
2-3 ~ 2-4	Selects print density	See "Selecting the Print Density (DIP Switches 2-3/2-4)" on page 47 .		OFF
2-5	Sets the release condition of the receive buffer BUSY state. (This function is effective when DIP Switch 1-2 is set to off.)	Releases the BUSY state when the remaining capacity of the receive buffer reaches 138 bytes.	Releases the BUSY state when the remaining capacity of the receive buffer reaches 256 bytes.	OFF
2-6 ~ 2-7	Reserved (Do not change settings)	Fixed to OFF		OFF
2-8	IF pin 31 reset signal (Do not change setting)	Fixed to ON		ON

CAUTION

- For DIP Switch 2-1 (BUSY condition), see also ["Selecting the BUSY Status" on page 48](#).
- Do not change the setting of DIP switches 2-2, 2-6, and 2-7. Otherwise, the printer may not operate normally.

For Built-in USB Interface

When using the serial or parallel interface, it is not necessary to change the DIP switch setting but their function changes. For the details, see ["For Serial Interface" on page 42](#) and ["For Parallel Interface" on page 44](#).

DIP Switch Bank 1

SW	Function	ON	OFF	Factory setting
1-1	Auto line feed	Always enabled	Always disabled	OFF
1-2	Receive buffer capacity	45 bytes	4 KB	OFF
1-3 ~ 1-6	Undefined	—		OFF
1-7	Undefined	—		*
1-8	Setting of USB power-saving function	Disabled	Enabled	OFF

* Varies depending on the interfaces.

DIP Switch Bank 2

SW	Function	ON	OFF	Factory setting
2-1	Handshaking (BUSY condition)	Receive buffer full	<ul style="list-style-type: none"> Offline Receive buffer full 	OFF
2-2	Reserved (Do not change setting)	Fixed to OFF		OFF
2-3 ~ 2-4	Selects print density	See "Selecting the Print Density (DIP Switches 2-3/2-4)" on page 47 .		OFF
2-5	Sets the release condition of the receive buffer BUSY state. (This function is effective when DIP Switch 1-2 is set to off.)	Releases the BUSY state when the remaining capacity of the receive buffer reaches 138 bytes.	Releases the BUSY state when the remaining capacity of the receive buffer reaches 256 bytes.	OFF
2-6 ~ 2-7	Reserved (Do not change settings)	Fixed to OFF		OFF
2-8	Reserved	—		*

* Varies depending on the interfaces.

CAUTION

- For DIP Switch 2-1 (BUSY condition), see also ["Selecting the BUSY Status" on page 48](#).
- Do not change the setting of DIP switches 2-2, 2-6, and 2-7. Otherwise, the printer may not operate normally.

For Ethernet/Wireless LAN/USB Interface

DIP Switch Bank 1

SW	Function	ON	OFF	Factory setting
1-1	Auto line feed	Always enabled	Always disabled	OFF
1-2	Receive buffer capacity	45 bytes	4 KB	OFF
1-3 ~ 1-8	Undefined	—		OFF

DIP Switch Bank 2

SW	Function	ON	OFF	Factory setting
2-1	Handshaking (BUSY condition)	Receive buffer full	<ul style="list-style-type: none"> • Offline • Receive buffer full 	OFF
2-2	Reserved (Do not change setting)	Fixed to OFF		OFF
2-3 ~ 2-4	Selects print density	See " Selecting the Print Density (DIP Switches 2-3/2-4) " on page 47.		OFF
2-5	Sets the release condition of the receive buffer BUSY state. (This function is effective when DIP Switch 1-2 is set to off.)	Releases the BUSY state when the remaining capacity of the receive buffer reaches 138 bytes.	Releases the BUSY state when the remaining capacity of the receive buffer reaches 256 bytes.	OFF
2-6 ~ 2-7	Reserved (Do not change settings)	Fixed to OFF		OFF
2-8	Reserved (Do not change setting)	Fixed to ON		ON

CAUTION

- For DIP Switch 2-1 (BUSY condition), see also "[Selecting the BUSY Status](#)" on page 48.
- Do not change the setting of DIP switches 2-2, 2-6, and 2-7. Otherwise, the printer may not operate normally.

Selecting the Print Density (DIP Switches 2-3/2-4)

Function	SW 2-3	SW 2-4
Do not set	ON	ON
Print density (standard)	OFF	OFF
Print density (darker than standard)	ON	OFF
Print density (dark)	OFF	ON

CAUTION

- If the print density is set to “Darker than standard” or “Dark” level, printing speed may be reduced.
- The print density can be set with DIP switches (2-3/2-4) or the customized value. (See ["Setting the Memory Switches \(Customized Value\)" on page 50.](#)) The initial setting of the customized value is “Depends on the DIP switch settings.” If the customized value is changed, the value set with the customized value is enabled.

Selecting the BUSY Status

With DIP switch 2-1, you can select conditions for invoking a BUSY state as either of the following:

- When the receive buffer is full
- When the receive buffer is full or the printer is offline

CAUTION

In either case above, the printer enters the BUSY state after power is turned on (including resetting with the interface) and when a self-test is being run.

Printer BUSY Condition and Status of DIP Switch 2-1

Printer status		DIP SW 2-1	
		ON	OFF
Offline	During the period after power is turned on (including resetting with the interface) to when the printer is ready to receive data.	BUSY	BUSY
	During the self-test.	BUSY	BUSY
	When the cover is open.	—	BUSY
	During paper feed with the Feed button.	—	BUSY
	When the printer stops printing due to a paper-end (when printer has run out of roll paper).	—	BUSY
	When waiting for the paper Feed button to be pressed before macro execution.	—	BUSY
	When an error has occurred.	—	BUSY
When the receive buffer becomes full.		BUSY	BUSY

Connecting the Power Supply Unit (PS-180)

Use the PS-180 or an equivalent product as the power supply unit.



- **Always use the EPSON PS-180 or an equivalent product as the power supply unit.** Using a nonstandard power supply can result in electric shock and fire.
- **Should a fault ever occur in the EPSON PS-180 or equivalent product, immediately turn off the power to the printer and unplug the power supply cable from the wall socket.**

Connecting the Power Supply Unit

- 1 Make sure the printer's power supply is turned off and the power supply unit's power cable has been unplugged from the wall socket.
- 2 Insert the connector of the power supply cable onto the power supply connector (stamped **24V**).



- **Be sure to unplug the power supply unit's cable from the wall socket whenever connecting or disconnecting the power supply unit to the printer.** Failure to do so may result in damage to the power supply unit or the printer.
- **Make sure the wall socket power supply satisfies the rated voltage requirements of the power supply unit. Never insert the power supply cable plug into a socket that does not meet the rated voltage requirements of the power supply unit.** Doing so may result in damage to both the power supply and the printer.



Before removing the DC cable connector from the PS-180, make sure the power supply cable has been removed from the power supply unit; then grasp the arrow-marked section of the connector and pull straight out.



The optional power supply box (OT-BX88V) is available. You can store the power supply unit in the box attached to the printer.

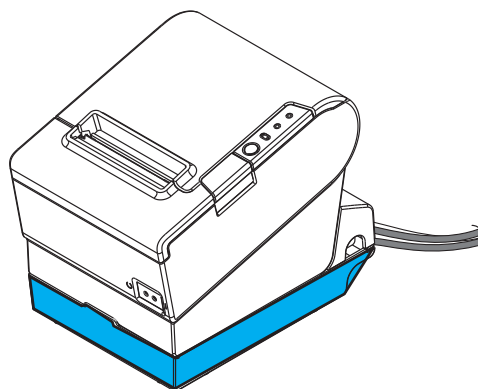

Setting the Memory Switches (Customized Value)

With the “memory switch (customized value),” a software switch for this printer, you can set the functions shown in the table below.

The memory switches (customized value) are already set. Change the setting if necessary.

For an outline of the functions, see the following section.

Use the methods in this table to set the memory switches (customized value).

	Memory Switch Setting Mode	TM-T88V Utility	ESC/POS Commands
Paper width	✓	✓	✓
Print density	✓	✓	✓
Multi-tone print density	✓	✓	✓
Print speed	✓	✓	✓
Font <ul style="list-style-type: none"> • Code page • International character set • Font A/B replacement 	✓	✓	✓
Optional Buzzer	✓	✓	✓
USB class	✓	✓	✓
Selection of interface mode	✓		✓
Number of head energizing parts	✓		✓
Power supply unit capacity	✓	✓	✓
Automatic paper cut	✓	✓	✓
Paper reduction <ul style="list-style-type: none"> • Upper space reduction • Lower space reduction • Line space reduction rate • Line feed reduction rate • Barcode height reduction rate 	✓	✓	✓
Transmission speed for serial interface	✓	✓	✓
Printer model*¹	✓		✓

*1: Setting printer model is also available with the TM-T88V Printer Model Setting Utility.

NOTE

- To directly configure the printer in the memory switch setting mode, see "[Memory Switch Setting Mode](#)" on page 90.
- For detailed information about the TM-T88V Utility, see the TM-T88V Utility User's Manual.
- For detailed information about ESC/POS commands, see the ESC/POS Application Programming Guide.

Functions

Setting the paper width

- 80 mm (initial setting)
- 58 mm

CAUTION

- Be sure to install the roll paper guide when you select the 58 mm paper width. (See "[Changing the Paper Width](#)" on page 39.)
- Once you change the paper width from 80 mm to 58 mm, you cannot change it back to 80 mm.

Setting the print density

Selectable from levels 1 to 13 (70% ~ 130%)

CAUTION

The print density can be set with DIP switches (2-3/2-4) or the customized value. (See "[Selecting the Print Density \(DIP Switches 2-3/2-4\)](#)" on page 47.) The initial setting of the customized value is "Depends on the DIP switch settings." If the customized value is changed, the value set with the customized value is enabled.

Setting the multi-tone print density

Selectable from levels 1 to 13 (70% ~ 130%)

CAUTION

- First change the print density, and then configure the Multi-tone print density.
- If you set the density too high, the contrast becomes lower. Select the density level checking the overall tone balance of your image.

Setting the print speed

Selectable from levels 1 to 13 (Slow ~ Fast) (initial setting: level 13)

NOTE

Depending on print conditions, such as print duty, print head temperature, and data transmission speed, print speed is automatically adjusted, which may cause white lines due to intermittent print (the motor sometimes stops). To avoid this, keep the print speed constant by setting it lower, or set the transmission speed higher for the serial interface. (See "[Transmission Speed \(DIP Switches 1-7/1-8\)](#)" on page 42.)

Setting font

- Code page: Selectable from 43 pages including user defined page
- International character set: Selectable from 18 sets
- Font A/B replacement

Optional Buzzer

When to sound the buzzer is selectable from the following occasions.

- When an error occurs
- When automatic paper cut activates
- When specified pulse 1 (2 pin) occurs
- When specified pulse 2 (5 pin) occurs

USB Class

- Printer Class
- Vendor Class

Selecting interface mode

Selectable from: automatic selection, fixed to UB interface, or fixed to built-in USB. Those 3 modes are described in both tables below.

NOTE

The TM-T88V has dual interfaces: a built-in USB interface and another interface selected by the customer. (The selectable interface is referred to as the “UB” interface.) The table below describes the modes you can set for the printer to control the dual interfaces.

For models with serial/parallel UB

Interface mode	UB	Built-in USB
Automatic selection (initial setting)	Available	Available
Fixed to UB	Available	Not available
Fixed to built-in USB	Not available	Available

For models with other UB

Interface mode	UB	Built-in USB
Automatic selection (initial setting)	Available	Not available
Fixed to UB	Available	Not available
Fixed to built-in USB	Not available	Available

NOTE
Automatic selection:

The interface of either the UB or built-in USB to which data is transmitted first is selected. Once the interface is selected, the selection is enabled until the power is turned off or the printer is reset.

Setting the number of head energizing parts

- One-part energizing (initial setting)
- Two-part energizing
- Four-part energizing

NOTE

- Usually, the number of head energizing parts does not need to be changed.
- The maximum print speed (300 mm/s) can be performed only when one-part energizing is selected.

Setting the power supply unit capacity

Selectable from levels 1 to 3 (Low ~ High) (initial setting: level 3)

Setting the automatic paper cut

- Not use this function (initial setting)
- Cut paper when the cover is closed
- Print logo when paper is cut

CAUTION

Printing logo when paper is cut is not available with memory switch setting mode.

Setting the paper reduction

- Extra upper space reduction: enabled or disabled (initial setting)
- Extra lower space reduction: enabled or disabled (initial setting)
- Line space reduction rate: not reduced (initial setting), 25%, 50%, or 75%
- Line feed reduction rate: not reduced (initial setting), 25%, 50%, or 75%
- Barcode height reduction rate: not reduced (initial setting), 25%, 50%, or 75%

Setting the transmission speed for serial interface

When DIP switches 1-7 and 1-8 are set to ON, the value (initially 38400) can be set to 2400, 4800, 9600, 19200, 38400, 57600, or 115200. (See "[Transmission Speed \(DIP Switches 1-7/1-8\)](#)" on page 42.)

Setting the printer model

When you use the TM-T88V with the APD Ver. 4.00 ~ 4.04, you need to change the printer model name to "TM-T88IV."

Adjusting the Paper Roll Near-End Sensor

Below are two situations where a roll paper NE sensor adjustment is required.

- To adjust the detection position to suit the diameter of the roll paper core used.
- To adjust the detection position of remaining amount of paper.

CAUTION

- Since roll paper cores vary slightly in shape, depending on paper roll design and manufacturing tolerances, it is impossible to detect the remaining paper exactly.
- Use roll paper with a core inner diameter of 12 mm {0.47"} and outer diameter of 18 mm {0.71"} so that the NE sensor can detect the remaining paper as accurately as possible.

Follow the steps below to adjust the roll paper near-end detector.

- 1 Open the roll paper cover, and remove the roll paper.
- 2 Loosen the adjustment screw fastening the sensor, and align the upper edge of the positioning plate with the adjustment position.

Adjustment position	Remaining amount of paper (outer diameter: mm)
Upper	Approx. 27 {1.06"}
Lower (Initial setting)	Approx. 23 {0.97"}

- 3 Tighten the adjustment screw.
- 4 After adjustment, make sure that the detection lever operates smoothly.

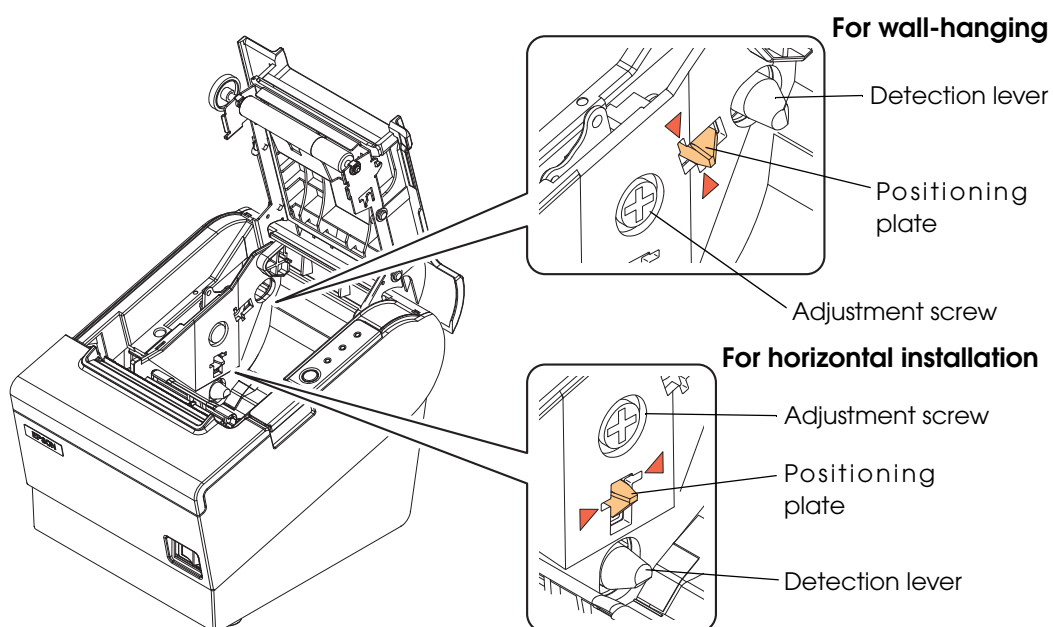

Connecting the Printer to the Host Computer

CAUTION

- Be sure to install the driver before connecting the printer to the host computer.
- The printer uses modular connectors specifically designed for the cash drawer. Do not connect these connectors to an ordinary telephone line.

For Serial Interface

Serial interface connection diagram

When this printer is connected to a host computer by the serial interface, two connection forms are possible:

- Stand alone
- Pass-through connection

Stand alone

This printer is connected to the host computer via the serial port. When a customer display (DM-D) is to be connected, connect it to the host computer via the serial port.

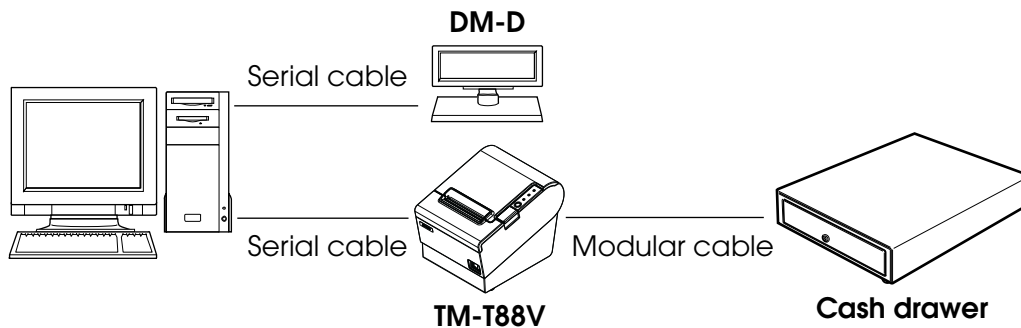

Pass-through connection

This printer is connected to the host computer over the serial interface via a customer display (DM-D).

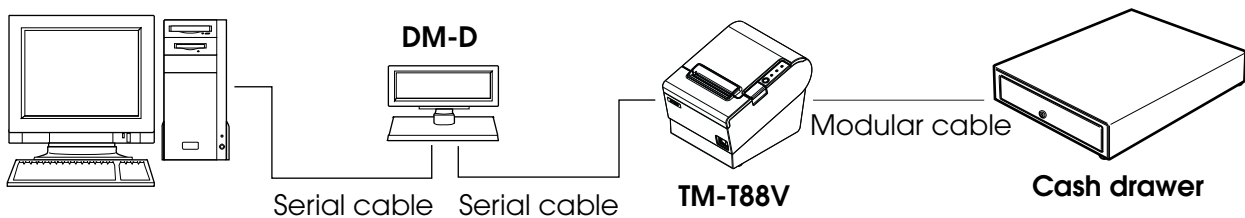

Connecting the serial interface (RS-232) cable



Be sure to turn off the power supply for both the printer and host computer before connecting the cables.

- 1** Insert the interface cable connector firmly into the interface connector on the connector panel.
- 2** When using connectors equipped with screws, tighten them to secure the connectors firmly.

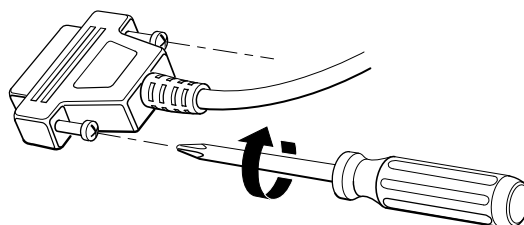

- 3** When using interface cables equipped with a grounding line, attach the ground line to the screw hole marked "FG" on the printer.
- 4** Connect the other end of the interface cable to the host computer.

For Parallel Interface

Parallel interface connection diagram

This printer is connected to the host computer via the parallel port. When a customer display (DM-D) is to be connected, connect it to the host computer via the serial port.

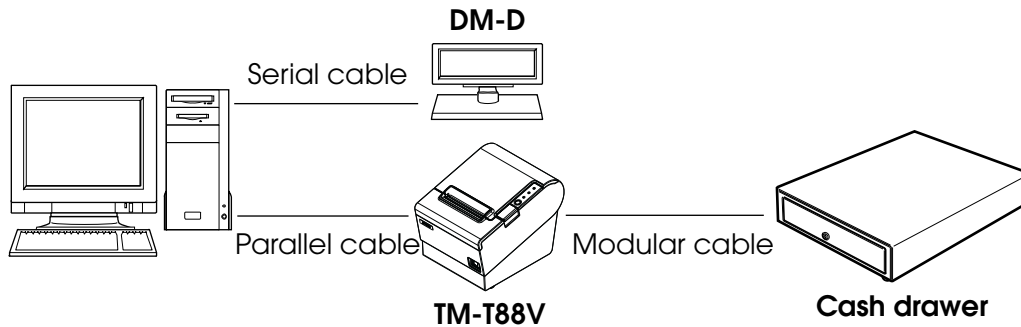

Connecting the parallel interface cable

- 1** Insert the interface cable connector firmly into the interface connector on the connector panel.
- 2** Press down the clips on either side of the connector to lock it in place.
- 3** When using interface cables equipped with a ground line, attach the ground line to the screw hole marked "FG" on the printer.
- 4** Connect the other end of the interface cable to the host computer.

For USB Interface

CAUTION

If you want to communicate via the built-in USB interface when you use a model with an interface other than the serial/parallel interface, you need to change the interface mode with the memory switch (customized value). To set the memory switch (customized value), see "[Setting the Memory Switches \(Customized Value\)](#)" on page 50.

USB interface connection diagram

When this printer is connected to the host computer by the USB interface, two connection forms are possible:

- Stand alone
- Y connection (only with the UB-U01III/U02III)

Stand alone

This printer is connected to the host computer via the USB port. When a customer display (DM-D) is to be connected, connect it to the host computer via the serial port.

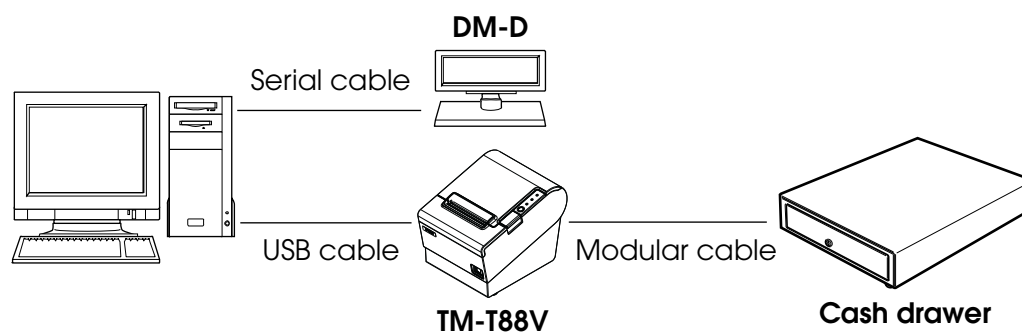

Y connection (only with the UB-U01III/U02III)

This printer is connected to the host computer via the USB port. When a customer display (DM-D) is to be connected, connect it to the printer via the modular cable.

CAUTION

- Make sure to pull out the power cable before connecting cables.
- When connecting a customer display to the printer, connect the modular jack from the customer display to the DM connector.
- Set the communication conditions of the customer display as follows:
 - * Baud rate: 19200 bps
 - * Bit length: 8-bit
 - * Parity: no parity
 - * Stop bit: 1

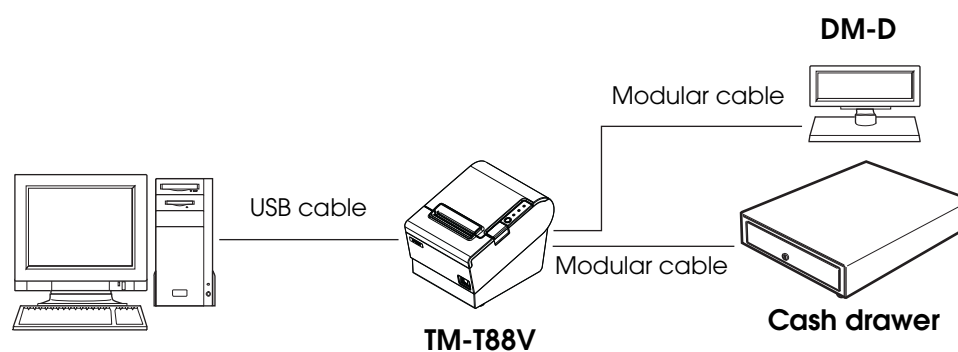

Connecting the built-in USB interface cable

- 1** Put the USB cable on the hook as shown in the figure, then connect it firmly to the built-in USB interface connector.
- 2** Connect the other connector of the cable to the host computer.

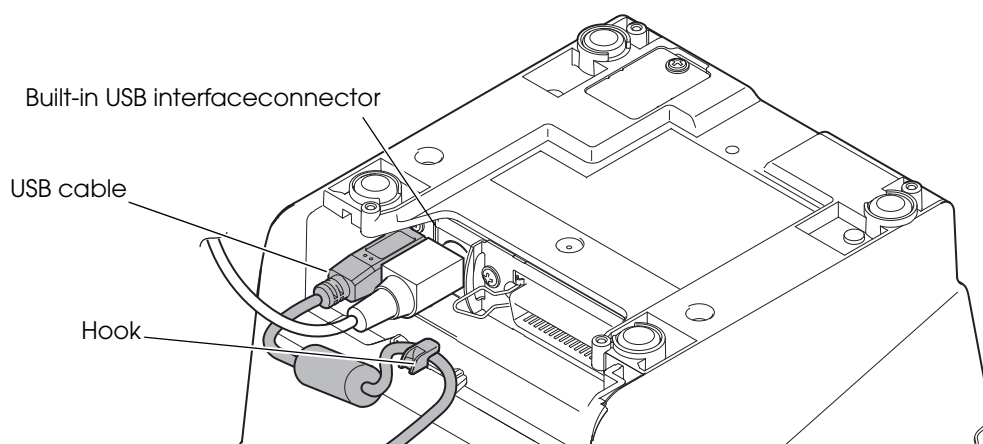

Connecting the USB interface cable

- 1 Attach the locking wire saddle at the location shown in the figure below.
- 2 Put the USB cable through the locking wire saddle.

CAUTION

Putting the USB cable through the locking wire saddle, as shown in the figure below, prevents the cable from coming unplugged.

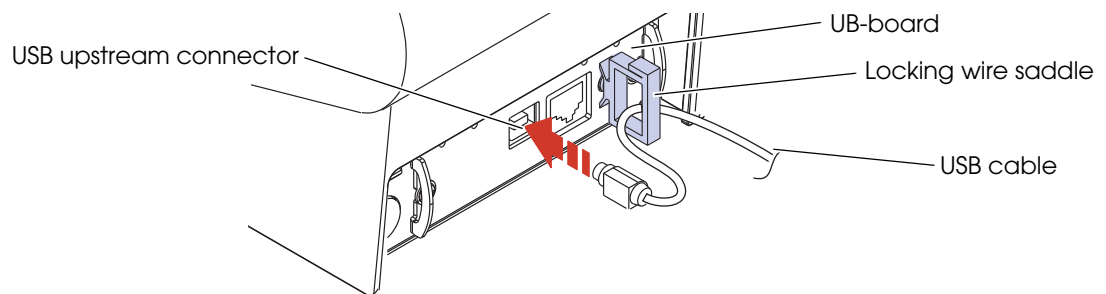

- 3 Connect the USB cable from the host computer to the USB upstream connector.

2

For Ethernet Interface

Connect the printer to a network by a LAN cable via a hub.

For the setting method of the IP address, see TM-T88V Software User's Manual.

Ethernet interface connection diagram

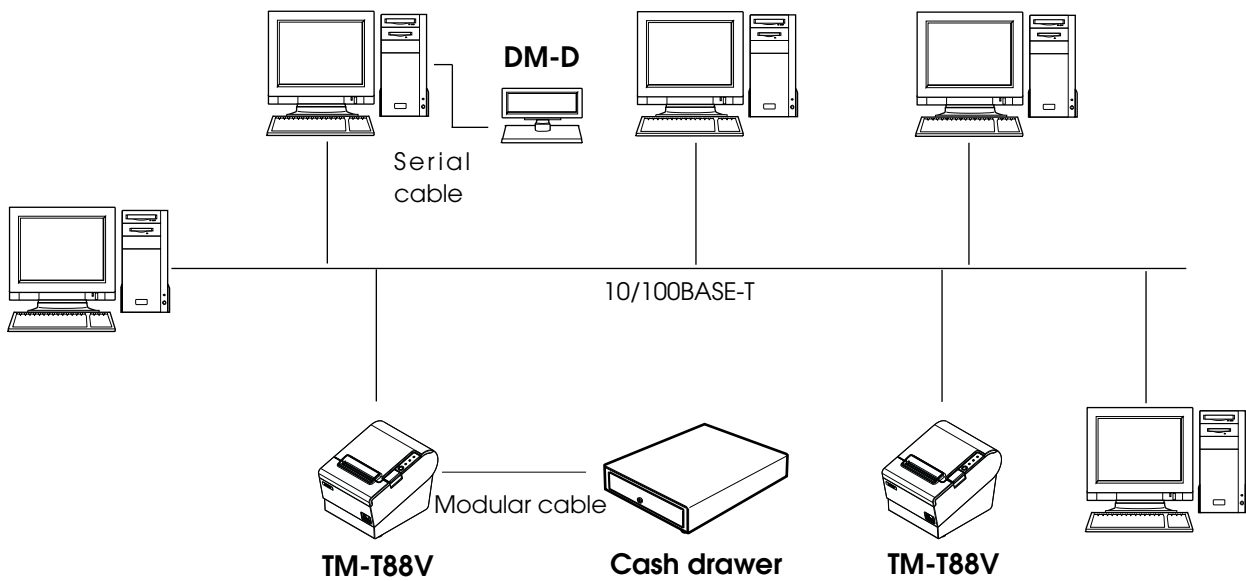

CAUTION

A customer display (DM-D series) cannot be connected to the printer when the printer is connected to the host computer. To connect the customer display, connect the printer to the host computer via the serial interface.

Connecting the Ethernet interface cable



CAUTION

- **When LAN cables are installed outdoors, make sure devices without proper surge protection are cushioned by being connected through devices that do have surge protection.**
Otherwise, the devices can be damaged by lightning.
- **Never attempt to connect the customer display cable, drawer kick-out cable, or the standard telephone line cable to the 10/100BASE-T LAN connector.**

Connect a 10/100BASE-T cable to the 10/100BASE-T LAN connector by pressing firmly until the connector clicks into place.

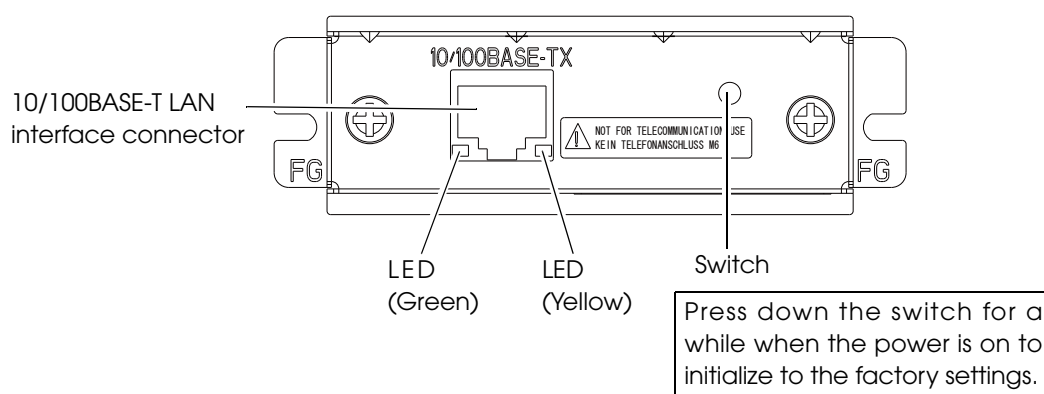

NOTE

When using the Ethernet interface, the network configuration is required. Make the settings using TM-T88V Utility.

For Wireless LAN Interface

For details on how to set up a wireless LAN interface, see the TM-T88V Software User's Manual.

Wireless LAN interface connection diagram

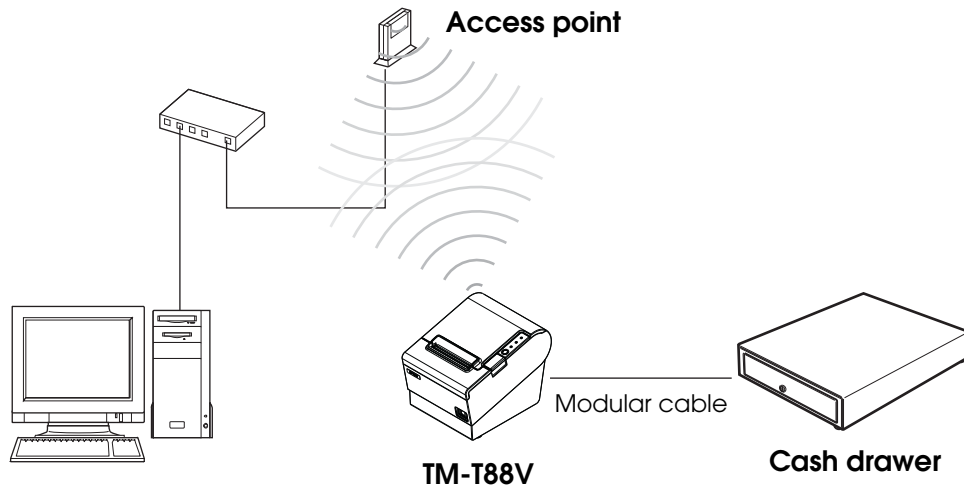

NOTE

When using the wireless LAN interface, the network configuration is required. Make the settings using TMNet WinConfig.

Connecting the Cash Drawer

When using a cash drawer, connect the cash drawer.

Use the cash drawer handled by EPSON or your dealer.

If the optional external buzzer is used, you cannot use a cash drawer.

Connecting the Drawer Kick-out Cable



- **Specifications of drawers differ depending on makers or models. When you use a drawer other than specified, make sure its specification meets the following conditions.**

Otherwise, devices may be damaged.

- * The load, such as a drawer kick-out solenoid, must be connected between pins 4 and 2 or pins 4 and 5 of the drawer kick-out connector.
- * When the drawer open/close signal is used, a switch must be provided between drawer kick-out connector pins 3 and 6.
- * The resistance of the load, such as a drawer kick-out solenoid, must be $24\ \Omega$ or more or the input current must be 1A or less.
- * Be sure to use the 24V power output on drawer-kick out connector pin 4 for driving the equipment.
- **Use a shield cable for the drawer connector cable.**
- **Two driver transistors cannot be energized simultaneously.**
- **Leave intervals longer than 4 times the drawer driving pulse when sending it continuously.**
- **Be sure to use the printer power supply (connector pin 4) for the drawer power source.**
- **Do not insert a telephone line into the drawer kick-out connector.**
Doing so may damage the telephone line or printer.

Connect the connector of the drawer kick-out cable to the printer.

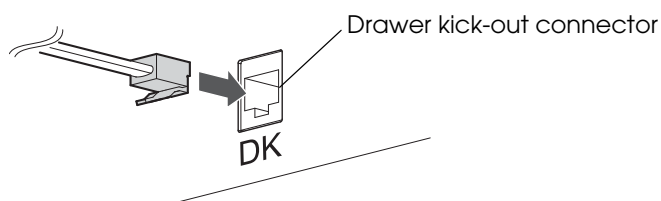

Drawer Connection Circuitry

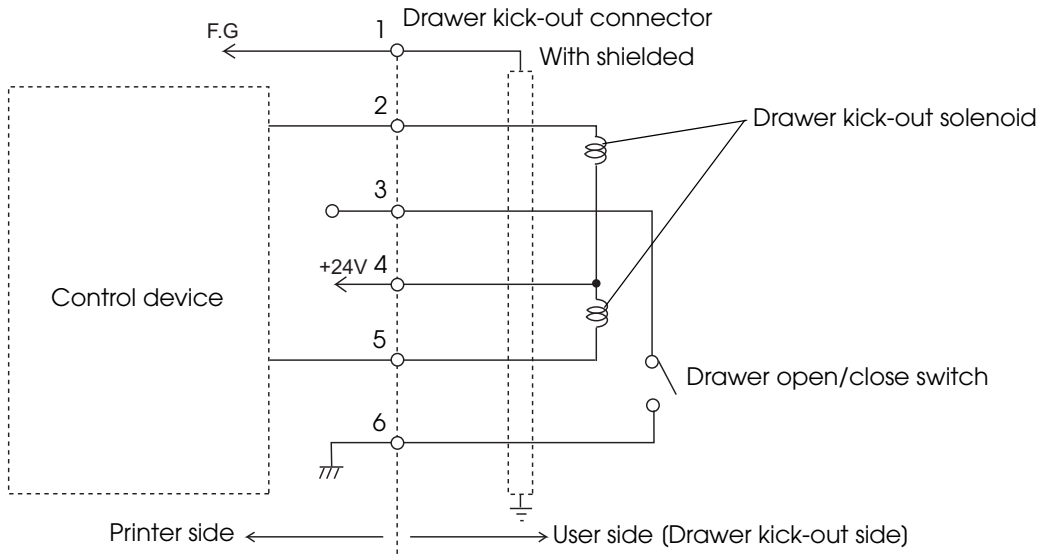

Setting the Internal Buzzer (for Model with an Internal Buzzer)

When using the internal buzzer, configure the buzzer.

Models with the buzzer function can beep the buzzer when the drawer is opened.

The buzzer setting is performed by setting the DIP switches for the buzzer and specifying connector pin numbers to which a command outputs a pulse signal.

DIP switch	Specified connector pin	ON	OFF	Initial setting
1	Drawer kick out connector pin 2	Buzzer beeps.	Buzzer does not beep.	ON
2	Drawer kick out connector pin 5	Buzzer beeps.	Buzzer does not beep.	OFF

CAUTION

Since the buzzer drive signal and the cash drawer drive signal are common in the printer, do not use the same connector pin numbers to output the signal for the buzzer and the cash drawer.

NOTE

For detailed information about ESC/POS commands, see the ESC/POS Application Programming Guide.

Connecting the Optional External Buzzer

When using the optional external buzzer (OT-BZ20), install the optional external buzzer.

If your printer is not equipped with a buzzer, you can use the optional external buzzer (OT-BZ20) by connecting it to the drawer.

CAUTION

- The optional external buzzer and the drawer cannot be used together at the same time.
- If you configure the memory switch (customized value) setting to enable the optional external buzzer, the drawer cannot be opened because the pulse is not sent to the drawer kick connector pin.
- Make sure to use the accessory magic tape (hook and loop fastener) to attach the optional external buzzer to the printer.
- Be careful not to spill water, oil, solvent, or any other liquid over the printer. Doing so may result in malfunction of the printer.

Unpacking

Open the package and confirm that it contains all of the parts listed in the illustration. If any parts are missing or damaged, please contact your dealer for assistance.

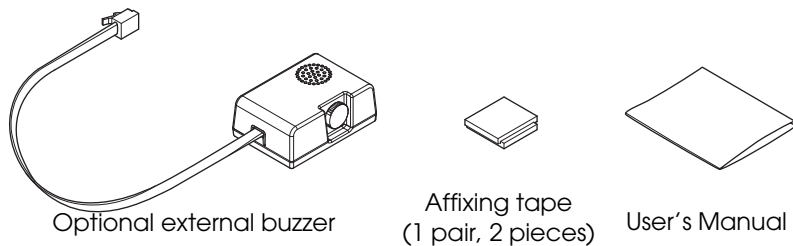

Installation Position

This product is recommended to be installed in the following positions.

- When using the printer horizontally: either side
- When using the printer vertically or on the wall:
either side/top/bottom (only for wall-hanging installation) *

* For the TM-T88V, the buzzer cannot be installed on the bottom

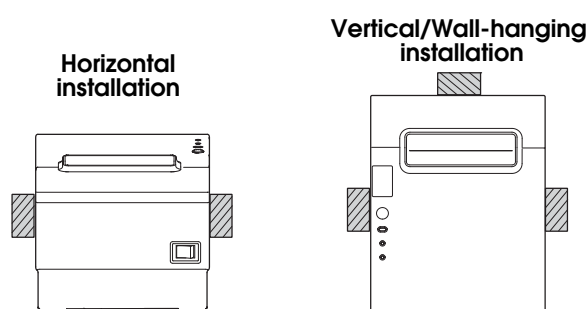

CAUTION

- Do not install the optional external buzzer at the roll paper exit.
- To prevent liquid from entering inside, it is recommended to install the optional external buzzer so that the volume adjustment knob is positioned sideways or downward. (For details of the volume adjustment knob, see ["Adjusting the Buzzer Volume" on page 71.](#))

Installation Procedures

1 Turn off the printer.

CAUTION

Connect and disconnect the optional external buzzer while the printer is turned off. If you connect it while the printer is turned on, the buzzer does not function correctly.

2 Clean and dry the printer case where the optional external buzzer will be installed.

3 With 2 pieces of the affixing tape combined, peel off the sticker on one side, and paste it around the center of the attaching surface of the optional external buzzer.

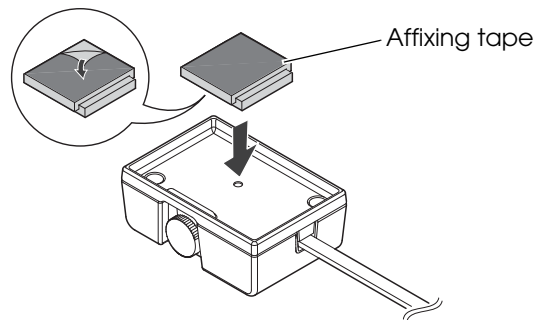

4 Connect the cable of the optional external buzzer to the drawer kick-out connector on the printer.

CAUTION

- Be sure to connect to the drawer kick-out connector on the applicable printer.
- Do not connect both the optional external buzzer and the drawer by using a splitter or similar device.

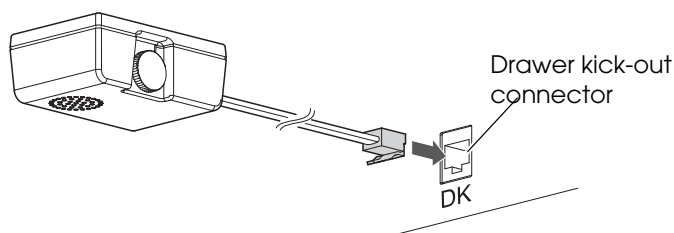

- 5** Peel off the sticker on the other side of the affixing tape, and attach and fix the optional external buzzer to the printer case.

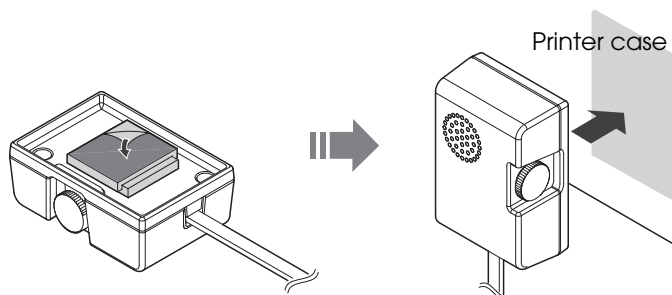

- 6** Turn on the printer.
- 7** Make settings for the optional external buzzer on the printer.

CAUTION

- To use this product, be sure to enable the optional external buzzer with the printer setting. For the details on the setting, see the Technical Reference Guide for each printer.
- When the optional external buzzer is enabled with the printer setting, the drawer cannot be driven.

Adjusting the Buzzer Volume

Turn the volume adjustment knob to adjust the buzzer volume.

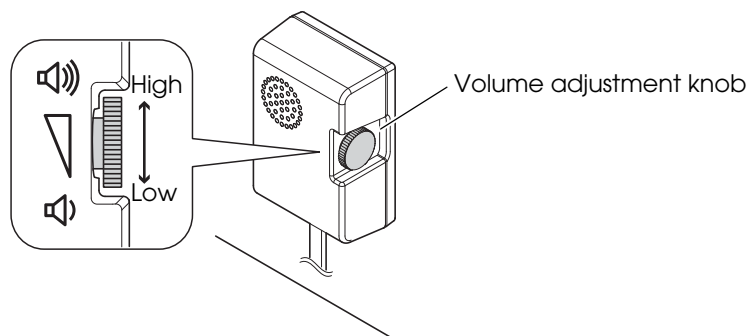

Setting the Optional External Buzzer

When and how to beep can be set by the driver, TM-T88V Utility or the printer's customized value. (See "[Setting the Memory Switches \(Customized Value\)](#)" on page 50.)

Attaching the Connector Cover

When using the connector cover, attach the connector cover.

Follow the steps below to attach the connector cover to protect cables.

- 1** Turn over the printer.
- 2** Position the two hooks on both sides of the connector cover so that they hook the printer case.

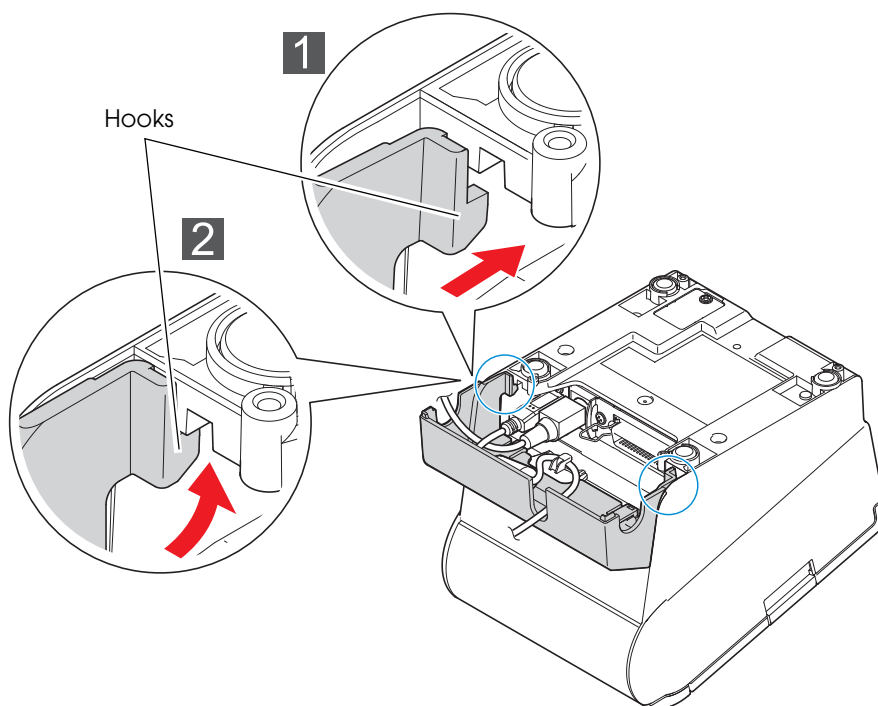

- 3** Push the connector cover down to click onto the printer case.
- 4** Pass each cable through the cable exits at the bottom of the connector cover.
- 5** Turn over the printer and make sure the cables are not pinched.

NOTE

- The serial, USB, or power cables can pass beneath the front of the printer so that the back of the printer looks uncluttered.

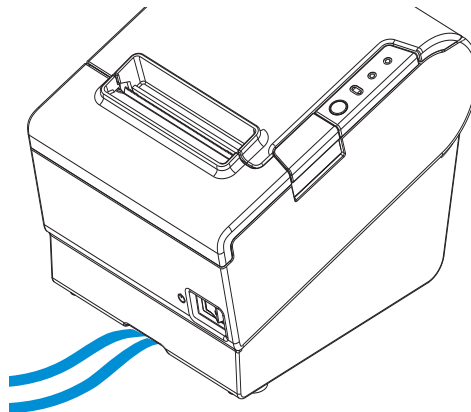

- To remove the connector cover, turn the printer over, and push the connector cover down while pushing both sides of the connector cover inward to detach the hooks from the printer case.

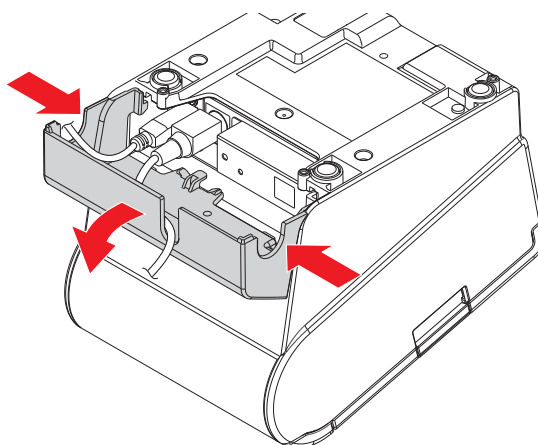

Arranging the Cables

Route the cables when using the connector cover.

Pass the cables through cable exits in the connector cover. The connector cover has cable exits on the back and both sides.

You can also route the cables out the front by passing them through the notch in the printer bottom.

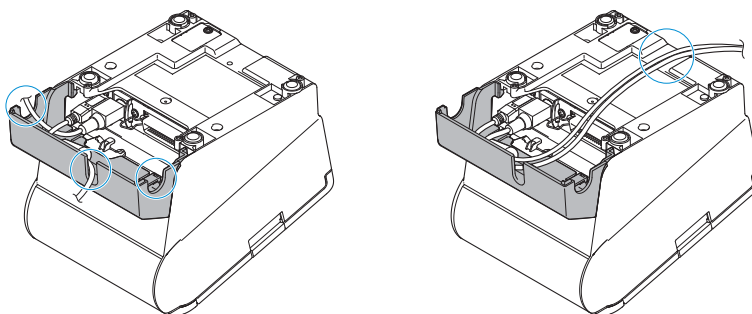

If you want to pass the USB cable through the cable exit on the back, fit the cable under the hook on the printer to prevent the cable from coming off.

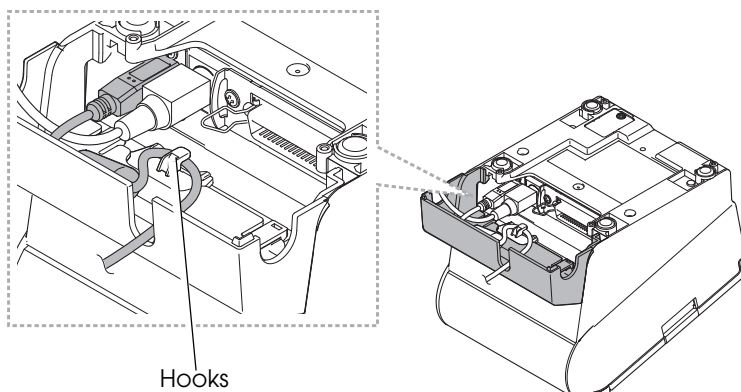

After the cable arrangement, turn over the printer, and make sure the cables are not pinched.

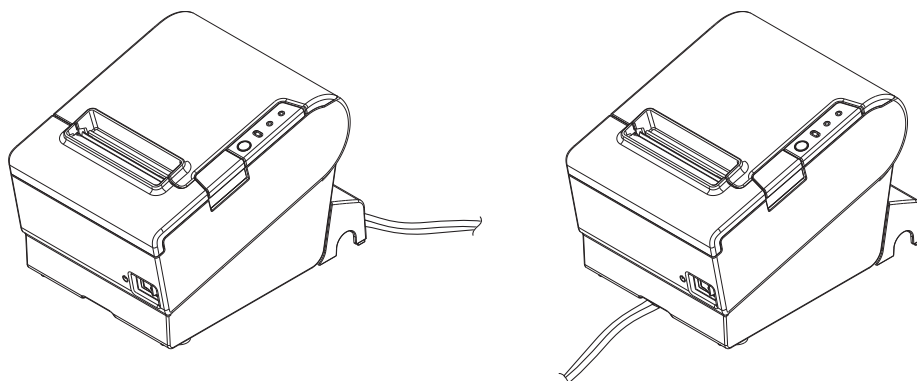

Application Development Information

This chapter describes how to control the printer and gives information useful for printer application development.

How to Control the Printer

Use a driver or ESC/POS commands to control the printer.

Selecting a Driver

Choose one of the drivers listed in "[Printer Drivers](#)" on page 81, depending on the application operating environment.

For information about the driver operating environment, see the installation manual for each driver.

When you newly develop an application

- Use APD if you want to print True Type fonts or print many graphics.
- OPOS ADK is recommended for system extensibility. An OPOS driver is provided for various peripherals and it is a POS industry standard now. It enables POS system efficiency, reduction of development cost, and effective use of application assets.

NOTE

You can use all functions, including ones not supported by OPOS ADK or APD, by using ESC/POS commands through your driver. Use the DIRECT I/O function of OPOS ADK, the control A command of APD, or Status API to send ESC/POS commands from each driver. (See "[ESC/POS command functions](#)" on page 76.)

ESC/POS Commands

ESC/POS is the Epson original printer command system. With ESC/POS commands, you can directly control all the TM printer functions, but detailed knowledge of printer specifications or combination of commands is required, compared to using a driver.

To use ESC/POS commands, you need to agree to a nondisclosure contract first and obtain the ESC/POS Application Programming Guide. Ask your dealer for details.

The ESC/POS command functions are listed below. See the ESC/POS Application Programming Guide for more details.

ESC/POS command functions

Commands for printing
Print and line feed
Print and feed <i>n</i> lines
Print data in page mode
Print and return to standard mode (in page mode)
Commands for line spacing
Set line spacing
Select default line spacing
Commands for print character
Select character code table
Select an international character set
Set right-side character spacing
Set all character fonts and styles
Turn underline mode on/off
Turn emphasized mode on/off
Select character font
Select character size
Turn smoothing mode on/off
Turn upside-down print mode on/off
Turn white/black reverse print mode on/off
Set character fonts and styles

Select/cancel user-defined character set
Define user-defined characters
Cancel print data in page mode
Commands for panel buttons
Enable/disable panel buttons
Commands for paper sensors
Select paper sensor(s) to stop printing
Select paper sensor(s) to output paper-end signals
Commands for print positions
Horizontal tab
Set horizontal tab positions
Set left margin
Set print area width
Select justification
Set absolute print position
Set relative print position
Set print area in page mode
Select print direction in page mode
Set absolute vertical print position in page mode
Set relative vertical print position in page mode
Commands for bit image
Transmit the NV graphic memory capacity
Print the graphics data in the print buffer
Transmit the remaining capacity of the NV graphics memory
Transmit the key code list for defined NV graphics
Delete the specified NV graphics data
Define the NV graphics data
Print the specified NV graphics data
Store the graphics data in the print buffer
Select bit-image mode

Define downloaded bit image
Print downloaded bit image
Register the Windows BMP in the NV graphics memory
Define Windows BMP NV graphics
Commands for status
Enable/disable Automatic Status Back (ASB)
Transmit status
Transmit real-time status
Commands for barcode
Print barcode
Set barcode height
Set barcode width
Select print position of HRI characters
Select font for HRI characters
Commands for two-dimensional codes
PDF417: Set the number of columns in the data region
PDF417: Set the number of rows
PDF417: Set the width of module
PDF417: Set the row height
PDF417: Set the error correction level
PDF417: Select the options
PDF417: Store the data in the symbol storage area
PDF417: Print the symbol data in the symbol storage area
PDF417: Transmit the size information of the symbol data in the symbol storage area
QR Code: Select the model
QR Code: Set the size of module
QR Code: Select the error correction level
QR Code: Store the data in the symbol storage area
QR Code: Print the symbol data in the symbol storage data area
QR Code: Transmit the size information of the symbol data in the symbol storage area

MaxiCode: Select the mode
MaxiCode: Store the data in the symbol storage area
MaxiCode: Print the symbol data in the symbol storage area
MaxiCode: Transmit the size information of the symbol data in the symbol storage area
Two-dimensional GS1 DataBar: Set the width of module
Two-dimensional GS1 DataBar: Set the maximum width of GS1 DataBar Expanded Stacked
Two-dimensional GS1 DataBar: Store the data in the symbol storage area
Two-dimensional GS1 DataBar: Print the symbol data in the symbol storage area
Two-dimensional GS1 DataBar: Transmit the size information of the symbol data in the symbol storage area
Composite Symbology: Set the width of module
Composite Symbology: Set the maximum width of GS1 DataBar Expanded Stacked
Composite Symbology: Select font for HRI characters
Composite Symbology: Store the data in the symbol storage area
Composite Symbology: Print the symbol data in the symbol storage area
Composite Symbology: Transmit the size information of the symbol data in the symbol storage area
Commands for mechanical control
Select cut mode and cut paper
Commands for customization
Set the customized setting values
Transmit the customized setting values
Set the configuration item for the serial interface
Transmit the configuration item for the serial interface
Delete the specified record of NV user memory
Store the data in the specified record of NV user memory
Transmit the data in the specified record of NV user memory
Transmit capacity of the NV user memory currently being used
Transmit the remaining capacity of the NV user memory
Transmit the key code list
Delete all data in the NV user memory

Commands for sub-functions
Initialize printer
Transmit printer ID
Set horizontal and vertical motion units
Select peripheral device
Generate pulse to drawer
Generate pulse to drawer in real-time
Execute power-off sequence
Clear buffer(s)
Enable/disable real-time command
Send real-time request to printer
Select page mode
Select standard mode
Set the process ID response
Execute test print
Select the print speed
Select the number of parts for the thermal head energizing
Initialize maintenance counter
Transmit maintenance counter
Commands for receipt enhancement
Enable/disable receipt enhancement function
Cancel set values for top/bottom logo printing
Transmit set values for top/bottom logo printing
Set top logo printing
Set bottom logo printing
Make extended settings for top/bottom logo printing
Enable/disable top/bottom logo printing

Software and Manuals

The following software and manuals are provided for application development.

Printer Drivers

Software	Manual
<p>EPSON Advanced Printer Driver (APD):</p> <p>In addition to ordinary Windows driver functions, this driver has controls specific to POS, such as controls for paper cut, a cash drawer, or customer display. The Status API (Epson original DLL) that monitors printer status and sends ESC/POS commands is also attached to this driver.</p>	<ul style="list-style-type: none"> • APD Install Manual • APD TM/BA/EU Printer Manual • APD Printer Specification • Devmode API/PRINTERINFO Manual • Status API Manual • Sample Program Guide • TM-T88V Software User's Manual
<p>EPSON OPOS ADK:</p> <p>This OCX driver can control POS peripherals using OLE technology*¹. Because controlling POS peripherals with original commands is not required on the application side, efficient system development is possible.</p>	<ul style="list-style-type: none"> • OPOS Installation Manual • User's Manual • Application Development Guide • UnifiedPOS Retail Peripheral Architecture*² • Sample Program Guide
<p>EPSON OPOS ADK for .NET:</p> <p>OPOS ADK for .NET allows you to develop applications that are compatible with Microsoft POS for .NET.</p> <p>When developing applications, use a separate development environment such as Microsoft Visual Studio .NET.</p>	<ul style="list-style-type: none"> • OPOS ADK for .NET Installation Guide • UnifiedPOS Retail Peripheral Architecture*² • User's Reference (SetupPOS) • Application Development Guide (POSPrinter TM-T88V)
<p>JavaPOS ADK (Windows/Linux):</p> <p>JavaPOS is the standard specification which defines an architecture and device interface (API) to access various POS devices from a Java based system. Using JavaPOS standard API allows control with Java-based applications of functions inherent to each device. A flexible design with Java language and JavaPOS enables many different types of computer systems, such as stand alone or network configuration, to use a same application. You can use JavaPOS to build applications and drivers independently of platforms. This allows flexible configurations using thin clients to meet the system requirements.</p>	<p>JavaPOS ADK Installation Guide</p>

Software	Manual
<p>EPSON TM Virtual Port Driver:</p> <p>This driver is a Serial-USB/Ethernet and Parallel-USB/Ethernet conversion driver to make an EPSON TM/BA/EU printer connected via USB/Ethernet accessible from a POS application through virtual COM ports and a virtual LPT port. Without making changes in the POS application that controls devices connected through serial or parallel interfaces, devices connected via USB/Ethernet can be directly controlled with ESC/POS commands.</p>	<p>TM Virtual Port Driver User's Manual</p>
<p>TM-T88V Mac Printer Driver:</p> <p>Mac printer driver allows you to control the TM-T88V using Common UNIX Printing System (CUPS) on Mac OS X.</p> <p>This is a full raster printer driver. It is able to print images, text, and vector graphics etc., that an application displays. With this driver many printer controls are possible, such as paper cut timing control, cash drawer control, printing speed control, blank line skip, and upside-down printing. It also provides API and dialogues for print setting, sample applications, and logo setting utility.</p>	<p>TM-T88V Mac Printer Driver User's Manual</p>
<p>Epson TM/BA Series Thermal Printer Driver:</p> <p>This driver allows you to control the TM-T88V using Common UNIX Printing System (CUPS) on GNU/Linux.</p> <p>This is a full raster printer driver. It is able to print images, text, and vector graphics etc., that an application displays. With this driver many printer control are possible, such as paper cut timing control, cash drawer control, printing speed control, blank line skip, and upside-down printing.</p>	<ul style="list-style-type: none"> • Epson TM/BA Series Thermal Printer Driver Installation Manual • Epson TM/BA Series Thermal Printer Driver Manual • TM-T88V Thermal Printer Driver Manual

*1: OLE technology developed by Microsoft divides software into part blocks. The OPOS driver is presupposed to be used with a development environment such as Visual Basic, unlike ordinary Windows drivers. It is not a driver to be used for printing from commercial applications.

*2: This guide describes general information on how to control printers using the OPOS ADK (in the chapter "POS Printer" and "Appendix-A"). It does not describe Epson's specific functions.

Utilities

Software	Manual
<p>TM-T88V Utility: Use for the following functions:</p> <ul style="list-style-type: none"> • Checking current settings • Operation check • Storing logos • Coupon settings • Paper reduction settings • Automatic paper cut settings • Printing control settings • Font settings • Optional buzzer settings • Communication I/F settings • Backup/restore 	<ul style="list-style-type: none"> • TM-T88V Software User's Manual • TM-T88V Utility User's Manual
<p>TM-T88V Printer Model Setting Utility: Use to change the printer model name when you use the TM-T88V with the APD Ver. 4.00 ~ 4.04.</p>	<ul style="list-style-type: none"> • TM-T88V Software User's Manual
<p>EPSON TMNet WinConfig: Use for IP address or wireless LAN setting.</p>	<ul style="list-style-type: none"> • TMNet WinConfig User's Guide • UB-E02/E03 Technical Reference Guide • UB-R03 Technical Reference Guide
<p>EpsonNet Simple Viewer: Use for checking the status of EPSON printers connected to a network and EPSON TM/BA printers connected to computers on a network.</p>	<p>EpsonNet Simple Viewer User's Manual</p>
<p>TM / BA /EU Printer Remote Configuration Tool: This is a package of EpsonNet Simple Viewer and TM-T88V Utility. First install this software in the computer with the administrator's authority, and set up the firewall. Next, install the printer driver in each client computer and set up the firewall. Then you can check the status of and configure the printer connected to a client computer on the network from the computer with the administrator's authority.</p>	<p>TM / BA /EU Printer Remote Configuration Tool User's Manual A package of EpsonNet Simple Viewer and TM-T88V Utility.</p>

Software	Manual
<p>BMP File Converter: Use to convert the BMP image files used in Windows into a data format which can be interpreted by EPSON POS printers (TM series). Conversion to multi-tone or black and white image command is possible. After execution a binary file with the command string is created.</p>	<p>Readme.txt File</p>

How to Get Drivers, Manuals, and the Utility

Drivers, manuals, and the TM-T88V Utility can be installed by the TM-T88V installer in the included the TM-T88V Software & Documents Disc.

You can also obtain them from one of the following URLs.

For customers in North America, go to the following web site:

<http://www.epsonexpert.com/> and follow the on-screen instructions.

For customers in other countries, go to the following web site:

<http://download.epson-biz.com/?service=pos>

Setting/Checking Modes

Besides the ordinary print mode, the printer has the following modes to set or check settings of the printer.

- Self-test Mode
- Hexadecimal Dumping Mode
- NV Graphics Print Mode
- Receipt Enhancement Information Print Mode
- Memory Switch Setting Mode

Self-test Mode

You can confirm the following information by running the self-test mode. You can also set the interface mode.

- Control circuit functions
- Printer mechanism
- Print quality
- ROM version
- Maintenance Information
- DIP switch settings

Follow the steps below to run this mode.

- 1 Close the roll paper cover.
- 2 While pressing the Feed button, turn on the printer. (Keep pressing the Feed button until the printer starts printing.)
The printer starts printing current status of the printer.

NOTE

With the LAN interface, before printing starts, it takes 6 seconds if the IP address is fixed and 13 seconds if the IP address is obtained with the automatic setting. (It may take longer depending on the response time from the host.)

When the printer finishes printing the printer status, the following message is printed and the Paper LED flashes. (The printer is now in the self-test wait mode.):

```

"Select Modes by pressing Feed button.
Continue SELF-TEST: Less than 1 second
Mode Selection      : 1 second or more"

```

-
- 3** Press the Feed button while the printer is in the self-test wait mode.
If you select the SELF-TEST, the printer prints a rolling pattern using only the built-in character set.
If you select the mode selection, follow the instructions printed by the printer.

After printing the following message, the printer is initialized and returned to the normal mode.

“*** completed***”

Hexadecimal Dumping Mode

In the hexadecimal dumping mode, the printer prints the data transmitted from a host computer in hexadecimal numbers and their corresponding characters.

Follow the steps below to run this mode.

CAUTION

- If there is no character corresponding to print data, "." is printed.
- If print data is less than one line, press the Feed button to print the line.
- Applications that confirm printer status may not work correctly during the hexadecimal dumping mode. The printer returns only the status for "Transmit real-time status."

- 1 Open the roll paper cover.
- 2 While pressing the Feed button, turn on the printer.
- 3 Close the roll paper cover.

The printer starts printing data received from then on in hexadecimal numbers and their corresponding characters.

Printing example:

```
Hexadecimal Dump
To terminate hexadecimal dump,
press FEED button three times.

1B 21 00 1B 26 02 40 40 1B 69 . ! . . & . @ @ . i
1B 25 01 1B 63 34 00 1B 30 31 . % . . c 4 . . 0 1
41 42 43 44 45 46 47 48 49 4A A B C D E F G H I J

*** completed ***
```

Turn off the printer or press the Feed button three times to return to the normal mode.

NV Graphics Print Mode

You can confirm the following information by running NV graphics print mode:

- Capacity of the NV graphics
- Used amount of the NV graphics
- Unused capacity of the NV graphics
- Number of NV graphics that are registered
- Key code, number of dots in X direction, number of dots in Y direction, number of colors to be defined.
- NV graphics data

NOTE

For detailed information about NV graphics, see "NV Graphics Memory" on page 23.

Follow the steps below to run this mode.

- 1** Close the roll paper cover.
- 2** While pressing the Feed button, turn on the printer. (Keep pressing the Feed button until the printer starts printing.)
The printer starts printing current status of the printer.
- 3** After the printing has been completed, press the Feed button for more than one second.
The printer starts printing instructions.
- 4** After the printing has been completed, press the Feed button.
- 5** Then press the Feed button for more than one second.

Turn the power off and on to return to the normal mode.

Receipt Enhancement Information Print Mode

You can confirm the following information by running the R/E information mode:

- Automatic top logo setting
- Automatic bottom logo setting
- Extended settings for automatic top/bottom logo

Follow the steps below to run this mode.

- 1** Close the roll paper cover.
- 2** While pressing the Feed button, turn the power on. (Keep pressing the Feed button until the printer starts printing.)
The printer prints current status of the printer.
- 3** After the printing has been completed, press the Feed button for more than one second.
The printer starts printing instructions.
- 4** After the printing has been completed, press the Feed button twice.
- 5** Then press the Feed button for more than one second.

Turn the power off and on to return to the normal mode.

Memory Switch Setting Mode

You can configure the memory switches (customized values) of the printer.

- Print density
- Communication conditions using a serial interface
- Auto reduction of the amount of paper to use
- Autocutting of paper while the cover is closed
- Paper width
- Default value of character code page/international character set
- Auto replacement of font
- Selection of an interface
- Selection of USB class
- Power supply capacity



For detailed information about memory switches (customized value), see ["Setting the Memory Switches \(Customized Value\)" on page 50.](#)

Follow the steps below to run this mode.

- 1** Close the roll paper cover.
- 2** Turn on the printer while pressing the Feed button.
The printer prints current status of the printer.
- 3** After the printing has been completed, press the Feed button for more than one second.
The printer starts printing instructions.
- 4** After the printing has been completed, press the Feed button three times.
- 5** Then press the Feed button for more than one second.
The printer starts printing instructions.

After one setting has been completed, the printer stores the setting and then starts initializing.
After that, the printer returns to the normal mode.

Handling

This chapter describes basic handling of the printer.

Installing and Replacing Roll Paper



- **Do not open the roll paper cover during printing.**
The printer may be damaged.
- **Do not touch the manual cutter with your hands when installing or replacing the roll paper.**
Otherwise, you may be injured because the manual cutter blade is sharp.



- Use roll paper that meets the printer specification. For details about paper specification, see "Paper Specifications" on page 31.
- Paper must not be pasted to the roll paper spool.

- 1** Press the cover open lever to open the roll paper cover.

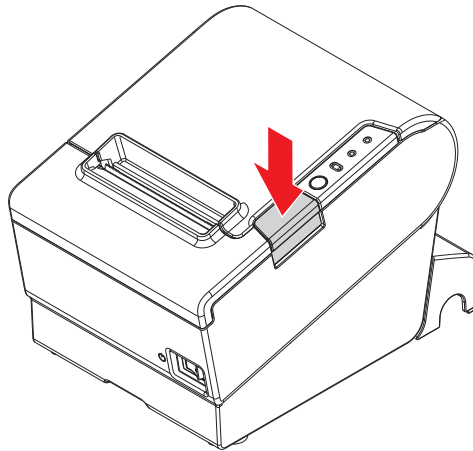

When the roll paper cover cannot be opened, see "[Removing Jammed Paper](#)" on page 93.

- 2** Remove the used roll paper core, if any.

- 3** Install the roll paper in the correct direction.

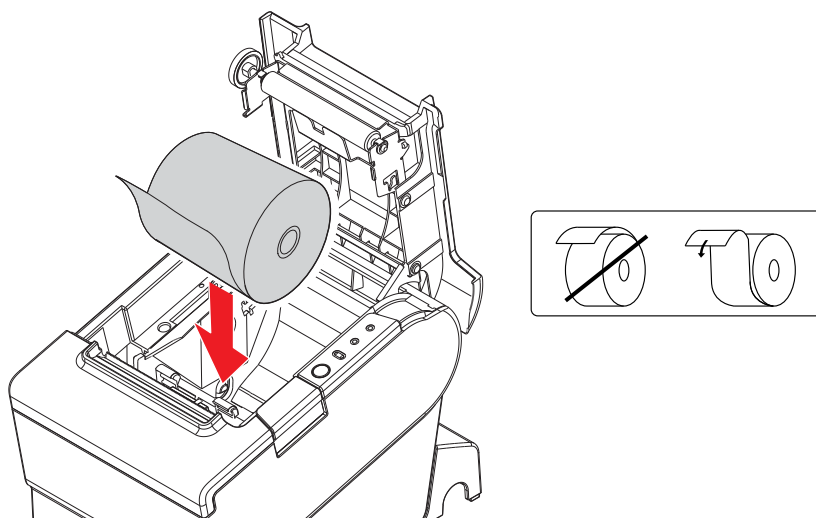

- 4** Pull out some roll paper, and close the roll paper cover.

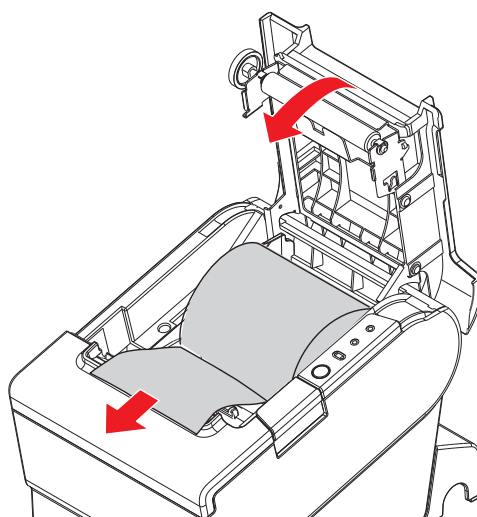

- 5** Tear off the roll paper with the manual cutter.

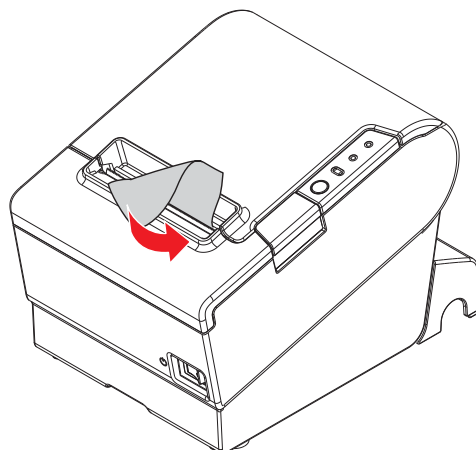

Removing Jammed Paper

When a paper jam occurs, never pull out the paper forcibly. Open the roll paper cover and remove the jammed paper.

When the roll paper cover cannot be opened, follow the steps below to remove the jammed paper.



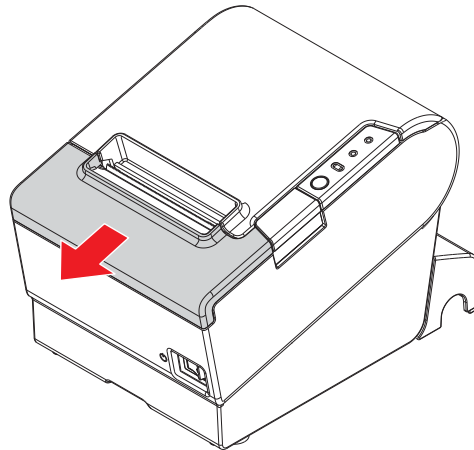

Do not touch the thermal head (See "[Cleaning the Thermal Head](#)" on page 95.) **because it can be very hot after printing.**

- 1** Turn off the printer.
- 2** Slide the cutter cover toward the front to open it.

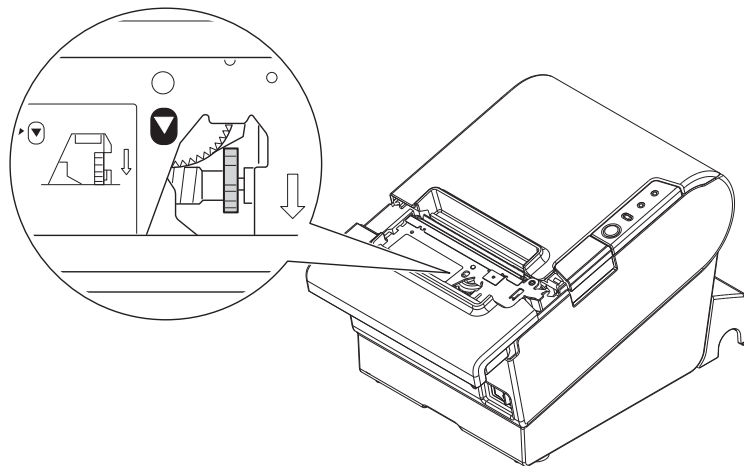

- 3** Turn the knob until you see a triangle in the opening.
This returns the cutter blade to the normal position. There is a label near the cutter to assist you.





4 Close the cutter cover.

5 Open the roll paper cover and remove the jammed paper.

Cleaning the Thermal Head

Epson recommends cleaning the thermal head periodically (generally every 3 months) to maintain receipt print quality.



After printing, the thermal head can be very hot. Do not touch it and let it cool before you clean it. Do not damage the thermal head by touching it with your fingers or any hard object.

Turn off the printer, open the roll paper cover, and clean the thermal elements of the thermal head with a cotton swab moistened with an alcohol solvent (ethanol or IPA).

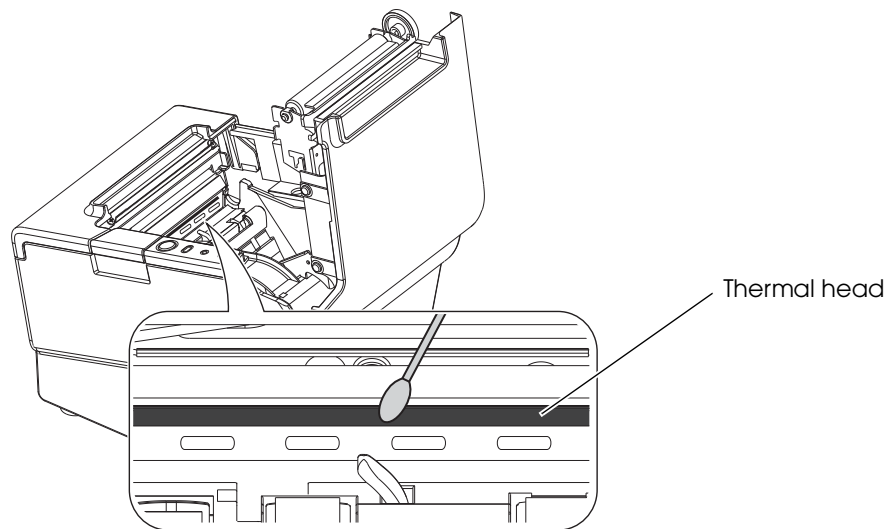

Depending on the roll paper used, paper dust may stick to the platen roller and roll paper end sensor. To remove the paper dust, clean the platen roller and roll paper end sensor with a cotton swab moistened with water. Turn on the printer power only after the water has completely dried.

Preparing for Transport

Follow the steps below to transport the printer.

- 1** Turn off the printer.
- 2** Remove the power supply connector.
- 3** Remove the roll paper.
- 4** Pack the printer upright.

Replacement of the TM-T88IV

The TM-T88V is designed so that it can smoothly replace the TM-T88IV. This chapter describes precautions for the replacement.

Compatibility

Printing

The printing and character specifications are the same as those of the TM-T88IV. Without special configurations, the TM-T88V prints the same results as the TM-T88IV prints.

Print Density

The print density of the TM-T88V can be set with DIP switches (2-3/2-4) as can the TM-T88IV. Set the density the same as for the TM-T88IV to print in the same print density.

NOTE

The print density can be set also with a customized value. The initial setting of the customized value is "Depends on the DIP switch settings." If the customized value is changed, the value set with the customized value is enabled. (See ["Setting the Memory Switches \(Customized Value\)"](#) on page 50.)

Two-Color Printing

You cannot use the paper for two-color printing (P320RB/P320BB) with the TM-T88V, which you can use with the TM-T88IV.

Number of Head Energizing Parts

For the TM-T88V, the initial setting of the number of head energizing parts is "One-part energizing." You can change the setting with the customized value (See ["Setting the Memory Switches \(Customized Value\)"](#) on page 50.); however it does not usually need to be changed.

	TM-T88V	TM-T88IV
Number of head energizing part	<ul style="list-style-type: none"> • One-part energizing • Two-part energizing • Four-part energizing 	<ul style="list-style-type: none"> • One-part energizing • Two-part energizing • Four-part energizing • Auto energizing

Printable Area (for 80 mm Width Paper)

The printable area (left/right margins, print start position from the autocutting position, print start position from the manual cutting position) of the TM-T88V is the same as that of the TM-T88IV.

Cutting Method

The TM-T88V uses the partial cutting method (cutting with one point in left edge left uncut) as does the TM-T88IV.

Manual Paper Feed

Manual paper feed is not possible with the TM-T88V while it is possible with the TM-T88IV after printing pauses.

Receive Buffer

You can set the receive buffer of the TM-T88V to 4KB or 45 bytes with DIP switch 1-2 as with the TM-T88IV. The buffer full condition and buffer full release condition of the TM-T88V are the same as those of the TM-T88IV.

Memory Capacity

The sizes of the download buffer and NV graphics data of the TM-T88V are the same as those of the TM-T88IV.

Electrical Characteristics

The operating voltage of the TM-T88V is $DC24 \pm 7\%$, the same as the TM-T88IV. The current consumption differs, depending on the print duty.

NOTE

The TM-T88V does not have a low power consumption mode, which the TM-T88IV has, so you cannot set DIP switches 2-3 and 2-4 to on. Use the newly added low power load mode instead.

DIP Switches

The functional assignments of DIP switches are the same as those of the TM-T88IV except for DIP switches 2-3 and 2-4.

Since the TM-T88V does not have a low power consumption mode, do not set DIP switches 2-3 and 2-4 both to ON.

Printer Status

The TM-T88V goes to the same status under the same conditions as the TM-T88IV. You can replace the TM-T88V with the TM-T88IV without modifying applications.

Logo Registration

The TM-T88V can register logos in the NV memory (NVRAM) with the TM-T88V Utility, while the TM-T88IV can register logos with the TM Flash LOGO Setup Utility for NVRAM (TM-Flogo).

NOTE

For detailed information about the TM-T88V Utility, see the TM-T88V Utility User's Manual.

Driver Compatibility

You can operate the TM-T88V with a driver for the TM-T88IV or the TM-T88III.

CAUTION

You cannot operate the TM-T88IV with a driver for the TM-T88V.

Advanced Printer Driver

When the TM-T88IV was controlled by APD Ver. 4.00 ~ 4.04, you need to change the TM-T88V printer model name to "TM-T88IV" using the customized value. (See "[Setting the Memory Switches \(Customized Value\)](#)" on page 50.)

When the TM-T88IV was controlled by an APD other than Ver. 4.00 ~ 4.04, you can replace it with the TM-T88V without modifying the APD.

OPOS ADK

If the TM-T88IV was controlled by an OPOS ADK, you can replace it with the TM-T88V without modifying the OPOS ADK.

USB Low Power Consumption Mode

With the TM-T88V, you can enable the USB low power consumption mode with DIP Switch 1-8, just as you can with the TM-T88IV. (See "For Ethernet/Wireless LAN/USB Interface" on page 46.)

Maintenance Counter

The TM-T88V has a maintenance counter just as the TM-T88IV has.

Buzzer

TM-T88V is available with a built-in buzzer or without the buzzer. Even if you purchase the one without the buzzer, you can attach an optional external buzzer. You can keep the buzzer with the pulse signal using a command. (See "[Setting the Internal Buzzer \(for Model with an Internal Buzzer\)](#)" on page 67, "[Connecting the Optional External Buzzer](#)" on page 68.)



For detailed information about ESC/POS commands, see the ESC/POS Application Programming Guide.

Power Supply Box

The optional power supply box (OT-BX88V) is available to be attached under the TM-T88V to hold the power unit, just as the OT-BX88 has been available for the TM-T88IV.

Overall Dimensions

You can place the TM-T88V in the same location as the TM-T88IV, since its overall dimensions and weight are about the same as or smaller than those of the TM-T88IV. With the wall hanging bracket (WH-10), you can attach the TM-T88V to a wall just as you can with the TM-T88IV.

<p>TM-T88V W:145 × D:195 × H:148 mm Approximately 1.6kg {W:5.71" × D:7.68" × H:5.83" Approximately 3.53 lb}</p>	<p>TM-T88IV W:148 × D:145 × H:195 mm Approximately 1.8kg {W:5.71" × D:7.68" × H:5.83" Approximately 3.97 lb}</p>

Additional Functions and Functional Improvements

Paper Width

You can change the printer to print on 58 mm width paper by installing the roll paper guide and changing the paper width setting with the customized value.

CAUTION

Once you change the paper width from 80 mm to 58 mm, you cannot change it back to 80 mm.

Print Speed

The TM-T88V has increased its print speed up to a maximum of 300 mm/s.

	TM-T88V	TM-T88IV
Maximum print speed	300 mm/s	200 mm/s
Print speed setting (Customized value)	Level 1 to 13	Level 1 to 9

Note: When the printer prints text (built-in fonts) with the default print density level at 24V and 25°C {77°F}.

CAUTION

Depending on print conditions such as print duty, print head temperature, and data transmission speed, print speed is automatically adjusted.

Barcodes

With the TM-T88V, printing the following barcodes, two-dimensional symbols and composite symbology is additionally possible.

- GS1-128
- GS1 DataBar Omnidirectional
- GS1 DataBar Truncated
- GS1 DataBar Stacked
- GS1 DataBar Stacked Omnidirectional
- GS1 DataBar Limited
- GS1 DataBar Expanded
- GS1 DataBar Expanded Stacked
- MaxiCode
- Composite Symbology

Number of Characters

For the TM-T88V, character code tables and international characters are added.

	TM-T88V	TM-T88IV
Character code tables	128 x 43 pages (including user-defined page)	128 x 11 pages (including user-defined page)
International characters	18 sets	14 sets

Image Tone Setting

The TM-T88V allows you to specify tone of images (2 tones/Grayscale).

Interface

The USB interface is added to the main unit of the TM-T88V as standard equipment.

USB Class

When using the built-in USB interface or USB Plus Power, USB printer class can be used beside the USB vendor-defined class. This setting can be done in customized value. (See "[Setting the Memory Switches \(Customized Value\)](#)" on page 50.)

Coupon Printing

The TM-T88V allows you to print coupons registered and set with the TM-T88V Utility.

NOTE

For detailed information about the TM-T88V Utility, see the TM-T88V Utility User's Manual.

Customized Value

For the TM-T88V, the following customized value functions are added.

- Paper width
- Multi-tone print density
- Initial value of the character code table
- Initial value of the international character set
- Optional buzzer
- USB class
- Interface mode
- Power supply unit capacity
- Automatic paper cut when the cover is closed
- Automatic paper-saving (upper space reduction)
- Automatic paper-saving (lower space reduction)
- Automatic paper-saving (line space reduction rate)
- Automatic paper-saving (line feed reduction rate)
- Automatic paper-saving (barcode height reduction rate)
- Font A replacement
- Font B replacement
- Printer model

For the TM-T88V, the following customized value functions are deleted.

- Single-color printing/two-color printing
- Black-color density in two-color printing

NOTE

For detailed information about the customized value, see "[Setting the Memory Switches \(Customized Value\)](#)" on page 50.

R/E Information Printing Mode

The TM-T88V has a Receipt Enhancement (R/E) Information Printing mode that lets you confirm the following information:

- Automatic top logo setting
- Automatic bottom logo setting
- Extended settings for automatic top/bottom logo

Low Power Load Mode

For the TM-T88V, there is a new low power load mode. In this mode, the power supply load is lowered by automatically changing the print speed, depending on the print duty. You can set the mode with the customized value. (See "[Setting the Memory Switches \(Customized Value\)](#)" on [page 50](#).)

Reliability

The TM-T88V has improved reliability.

		TM-T88V	TM-T88IV
Life	Printer mechanism	20 million lines	15 million lines
	Print head	150 million pulse, 150 km	100 million pulse, 100 km
	Autocutter	2 million cuts	1.5 million cuts
MCBF		70 million lines	52 million lines



Appendix

Specifications of Interfaces and Connectors

NOTE

For detailed information about LAN or wireless LAN, see one of the following:

- LAN: UB-E02 Technical Reference Guide
- Wireless LAN: UB-R02/R03 Technical Reference Guide

RS-232 Serial Interface

Interface board specifications (RS-232-compliant)

Item		Specifications
Data transfer method		Serial
Synchronization		Asynchronous
Handshake		Select one of the following with DIP switch 1-3: <ul style="list-style-type: none"> • DTR/DSR • XON/XOFF
Signal level	MARK	-3V to -15V logic "1"/OFF
	SPACE	+3V to +15V logic "0"/ON
Bit length		Select one of the following with DIP switch 1-4: <ul style="list-style-type: none"> • 7 bit • 8 bit
Transmission speed (bps: bits per second)		<ul style="list-style-type: none"> • Select one of the following with DIP switch 1-7/1-8: 4800/9600/19200/38400 bps • Select one of the following with commands: 2400/4800/9600/19200/38400/57600/115200 bps
Parity check		Select one of the following with DIP switch 1-5: <ul style="list-style-type: none"> • Yes • No
Parity selection		Select one of the following with DIP switch 1-6: <ul style="list-style-type: none"> • Even • Odd
Stop bit		1 or more bits However, the stop bit for data transfer from the printer is fixed to 1 bit.
Connector	Printer side	DSUB 25-pin (female) connector

Functions of each connector pin

Pin no.	Signal name	Signal direction	Function
1	FG	—	Frame ground
2	TXD	Output	Transmission data
3	RXD	Input	Reception data
4	RTS	Output	Equivalent to DTR signal (pin 20)
6	DSR	Input	<p>This signal indicates whether the host computer can receive data.</p> <p>SPACE indicates that the host computer can receive data. MARK indicates that the host computer cannot receive data.</p> <p>When DTR/DSR control is selected, the printer transmits data after confirming this signal (except if transmitted using some ESC/POS commands).</p> <p>When XON/XOFF control is selected, the printer does not check this signal.</p> <p>Changing DIP switch 2-7 lets this signal be used as a printer reset signal.</p> <p>When you use this signal as the printer's reset signal, the printer is reset when the signal remains MARK for a pulse width of 1 ms or more.</p>
7	SG	—	Signal ground
20	DTR	Output	<p>1) When DTR/DSR control is selected, this signal indicates whether the printer is BUSY.</p> <ul style="list-style-type: none"> • SPACE status <p>Indicates that the printer is ready to receive data.</p> <ul style="list-style-type: none"> • MARK status <p>Indicates that the printer is BUSY. Set BUSY conditions with DIP switch 2-1.</p> <p>2) When XON/XOFF control is selected, the signal indicates that the printer is properly connected and ready to receive data from the host. The signal is always SPACE, except in the following cases:</p> <ul style="list-style-type: none"> • During the period from when power is turned on to when the printer is ready to receive data. • During the self-test.
25	INT	Input	<p>Changing DIP switch 2-8 enables this signal to be used as a reset signal for the printer. The printer is reset if the signal remains at SPACE for a pulse width of 1 ms or more.</p>

XON/XOFF

When XON/XOFF control is selected, the printer transmits the XON or XOFF signals as follows. The transmission timing of XON/XOFF differs, depending on the setting of DIP switch 2-1.

Signal	Printer status	DIP switch 2-1	
		1 (ON)	0 (OFF)
XON	1) When the printer goes online after turning on the power (or reset using the interface)	Transmit	Transmit
	2) When the receive buffer is released from the buffer full state	Transmit	Transmit
	3) When the printer switches from offline to online	—	Transmit
	4) When the printer recovers from an error using some ESC/POS commands	—	Transmit
XOFF	5) When the receive buffer becomes full	Transmit	Transmit
	6) When the printer switches from online to offline	—	Transmit

Code

The hexadecimal numbers corresponding to the XON/XOFF codes are shown below.

- XON code: 11H
- XOFF code: 13H



- When the printer goes from offline to online and the receive buffer is full, XON is not transmitted.
- When the printer goes from online to offline and the receive buffer is full, XOFF is not transmitted.
- When DIP switch 1-3 is off, XON is not transmitted as long as the printer is offline, even if a receive buffer full state has been cleared.

IEEE 1284 Parallel Interface

Modes

The IEEE 1284 parallel interface supports the following two modes.

Mode	Communication direction	Other information
Compatibility mode	Host → Printer communication	Centronics-compliant
Reverse mode	Printer → Host communication	Assumes a data transfer from an asynchronous printer

Compatibility Mode

Compatibility mode allows data transmission from host to printer only: Centronics-compatible.

Specification

Data transmission	8-bit parallel
Synchronization	Externally supplied $\overline{\text{STROBE}}$ signals
Handshaking	$\overline{\text{ACK}}$ and BUSY signals
Signal levels	TTL-compatible connector
Connector	ADS-B36BLFDR176 (HONDA) or equivalent product
Reverse communication	Nibble or byte mode

Reverse Mode

The transfer of status data from the printer to the host proceeds in the nibble or byte mode.

This mode allows data transfer from an asynchronous printer under the control of the host. Data transfers in the nibble mode are made via the existing control lines in units of four bits (a nibble). In the byte mode, data transfer proceeds by making the 8-bit data lines bidirectional. Both modes fail to proceed concurrently in the compatibility mode, thereby causing half-duplex transmission.

Interface signals

Pin	Source	Compatibility Mode	Nibble Mode	Byte Mode
1	Host	Strobe	HostClk	HostClk
2	Host/Ptr	Data0 (LSB)	Data0 (LSB)	Data0 (LSB)
3	Host/Ptr	Data1	Data1	Data1
4	Host/Ptr	Data2	Data2	Data2
5	Host/Ptr	Data3	Data3	Data3
6	Host/Ptr	Data4	Data4	Data4
7	Host/Ptr	Data5	Data5	Data5
8	Host/Ptr	Data6	Data6	Data6
9	Host/Ptr	Data7 (MSB)	Data7 (MSB)	Data7 (MSB)
10	Printer	$\overline{\text{Ack}}$	PtrClk	PtrClk
11	Printer	Busy	PtrBusy/Data3,7	PtrBusy
12	Printer	Perror	AckDataReq/Data2,6	AckDataReq
13	Printer	Select	Xflag/Data1,5	Xflag
14	Host	$\overline{\text{AutoFd}}$	HostBusy k	HostBusy
15		NC	ND	ND
16		GND	GND	GND
17		FG	FG	FG
18	Printer	Logic-H	Logic-H	Logic-H
19		GND	GND	GND
20		GND	GND	GND
21		GND	GND	GND
22		GND	GND	GND
23		GND	GND	GND
24		GND	GND	GND
25		GND	GND	GND
26		GND	GND	GND
27		GND	GND	GND

Pin	Source	Compatibility Mode	Nibble Mode	Byte Mode
28		GND	GND	GND
29		GND	GND	GND
30		GND	GND	GND
31	Host	$\overline{\text{Init}}$	$\overline{\text{Init}}$	$\overline{\text{Init}}$
32	Printer	$\overline{\text{Fault}}$	$\overline{\text{DataAvail/Data0,4}}$	$\overline{\text{DataAvail}}$
33		GND	ND	ND
34	Printer	DK_STATUS	ND	ND
35	Printer	+5V	ND	ND
36	Host	$\overline{\text{SelectIn}}$	1284-Active	1284-Active

NC: Not Connected

ND: Not Defined



- A signal name with a rule above it indicates an “L” active signal.
- Bidirectional communications cannot take place, unless all signal names for both sides correspond to each other.
- Connect all signal lines using a twisted-pair cable. Connect the return side to the signal ground level.
- Make sure the signals satisfy electrical characteristics.
- Set the leading edge and trailing edge times to 0.5ms or less.
- Do not ignore $\overline{\text{Ack}}$ or BUSY signals during a data transfer. Ignoring such signals may result in data corruption.
- Make the interface cables as short as possible.

USB (Universal Serial Bus) Interface

Outline

- Full-speed transmission at 12 Mbps [bps: bits per second]
- Plug & Play, Hot Insertion & Removal

USB transmission specifications

USB function

Overall specifications	According to USB 2.0 specifications
Transmission speed	USB Full-Speed (12 Mbps)
Transmission method	USB bulk transmission method
Power supply specifications	USB self power supply function
Current consumed by USB bus	0 mA
USB packet size (with full-speed connection)	
USB bulk OUT (TM)	64 bytes
USB bulk IN (TM)	64 bytes

Status transmission from printer with USB interface

In order to ensure that there is no lack of status data, it is necessary to periodically retrieve status data at the host computer.

Unlike RS 232C transmission, it cannot spontaneously interrupt data transmission to the host computer.

The printer has a 128-byte status data buffer. Statuses that exceed the buffer capacity are canceled.

Character Code Tables

CAUTION



- The character code tables show only character configurations. They do not show the actual print pattern.
- "SP" in the table shows a space.

Common to All Pages

When International character set (See "[International Character Sets](#)" on page 158.) is USA:

HEX	0	1	2	3	4	5	6	7
0	NUL 00	DLE 16	SP 32	0 48	@ 64	P 80	` 96	p 112
1		XON 17	! 33	1 49	A 65	Q 81	a 97	q 113
2			" 34	2 50	B 66	R 82	b 98	r 114
3		XOFF 19	# 35	3 51	C 67	S 83	c 99	s 115
4	EOT 04	DC4 20	\$ 36	4 52	D 68	T 84	d 100	t 116
5	ENQ 05	NAK 21	% 37	5 53	E 69	U 85	e 101	u 117
6	ACK 06		& 38	6 54	F 70	V 86	f 102	v 118
7			' 39	7 55	G 71	W 87	g 103	w 119
8		CAN 24	(40	8 56	H 72	X 88	h 104	x 120
9	HT 09) 41	9 57	I 73	Y 89	i 105	y 121
A	LF 10		* 42	: 58	J 74	Z 90	j 106	z 122
B		ESC 27	+ 43	; 59	K 75	[91	k 107	{ 123
C	FF 12	FS 28	, 44	< 60	L 76	¥ 92	l 108	 124
D	CR 13	GS 29	- 45	= 61	M 77] 93	m 109	} 125
E		RS 30	. 46	> 62	N 78	^ 94	n 110	~ 126
F			/ 47	? 63	O 79	_ 95	o 111	SP 127









Page 0 (PC437: USA, Standard Europe)

HEX	8	9	A	B	C	D	E	F
0	Ç 128	É 144	á 160	 176	L 192	⌌ 208	α 224	≡ 240
1	ü 129	æ 145	í 161	 177	⌐ 193	⌑ 209	β 225	± 241
2	é 130	Æ 146	ó 162	 178	⌒ 194	⌒ 210	Γ 226	≥ 242
3	â 131	ô 147	ú 163	 179	⌓ 195	⌌ 211	π 227	≤ 243
4	ä 132	ö 148	ñ 164	⌔ 180	— 196	⌑ 212	Σ 228	∫ 244
5	à 133	ò 149	Ñ 165	⌕ 181	⌕ 197	⌑ 213	σ 229	∫ 245
6	å 134	û 150	ä 166	⌖ 182	⌕ 198	⌑ 214	μ 230	÷ 246
7	ç 135	ù 151	º 167	⌗ 183	⌕ 199	⌑ 215	τ 231	≈ 247
8	ê 136	ÿ 152	¿ 168	⌘ 184	⌌ 200	⌑ 216	Φ 232	° 248
9	ë 137	Ö 153	Г 169	⌙ 185	⌑ 201	⌑ 217	Θ 233	• 249
A	è 138	Ü 154	Г 170	⌚ 186	⌌ 202	⌑ 218	Ω 234	· 250
B	ï 139	ø 155	½ 171	⌛ 187	⌑ 203	■ 219	δ 235	√ 251
C	î 140	£ 156	¼ 172	⌜ 188	⌑ 204	■ 220	∞ 236	ⁿ 252
D	ì 141	¥ 157	ı 173	⌝ 189	= 205	■ 221	Φ 237	² 253
E	Ä 142	ƒ 158	« 174	⌞ 190	⌑ 206	■ 222	ε 238	■ 254
F	Å 143	f 159	» 175	⌟ 191	⌌ 207	■ 223	∩ 239	SP 255

HEX	8	9	A	B	C	D	E	F
0	▬ 128	┘ 144	SP 160	- 176	々 192	≡ 208	= 224	× 240
1	■ 129	┘ 145	。 161	ア 177	チ 193	ム 209	フ 225	円 241
2	■ 130	┘ 146	「 162	イ 178	ツ 194	メ 210	≠ 226	年 242
3	■ 131	┘ 147	」 163	ウ 179	テ 195	モ 211	≡ 227	月 243
4	■ 132	- 148	、 164	エ 180	ト 196	ヤ 212	▲ 228	日 244
5	■ 133	- 149	・ 165	オ 181	ナ 197	ユ 213	▲ 229	時 245
6	■ 134	150	ヲ 166	カ 182	ニ 198	ヨ 214	▼ 230	分 246
7	■ 135	151	ア 167	キ 183	ヌ 199	ラ 215	▼ 231	秒 247
8	136	「 152	イ 168	ク 184	ネ 200	リ 216	♠ 232	千 248
9	137	┘ 153	ウ 169	ケ 185	ノ 201	ル 217	♥ 233	市 249
A	138	┘ 154	エ 170	コ 186	ハ 202	レ 218	♦ 234	区 250
B	139	┘ 155	オ 171	サ 187	ヒ 203	ロ 219	♣ 235	町 251
C	140	┘ 156	ヤ 172	シ 188	フ 204	ワ 220	● 236	村 252
D	141	┘ 157	ユ 173	ス 189	ヘ 205	ソ 221	○ 237	人 253
E	142	┘ 158	ヨ 174	セ 190	ホ 206	ド 222	/ 238	■ 254
F	┘ 143	┘ 159	ツ 175	ソ 191	マ 207	。 223	\ 239	SP 255









Page 2 (PC850: Multilingual)

HEX	8	9	A	B	C	D	E	F
0	Ç 128	É 144	á 160	◌ 176	Ł 192	ð 208	Ó 224	- 240
1	ü 129	æ 145	í 161	◌ 177	⊥ 193	Ð 209	β 225	± 241
2	é 130	Æ 146	ó 162	◌ 178	⊥ 194	Ê 210	Ô 226	= 242
3	â 131	ô 147	ú 163	 179	⊥ 195	Ë 211	Ò 227	¾ 243
4	ä 132	ö 148	ñ 164	⊥ 180	- 196	È 212	õ 228	¶ 244
5	à 133	ò 149	Ñ 165	Á 181	† 197	ı 213	Õ 229	§ 245
6	å 134	û 150	ä 166	Â 182	ã 198	Í 214	μ 230	÷ 246
7	ç 135	ù 151	º 167	À 183	Ã 199	Î 215	þ 231	˘ 247
8	ê 136	ÿ 152	¿ 168	© 184	ℒ 200	Ï 216	Ɔ 232	° 248
9	ë 137	Ö 153	® 169	‡ 185	℞ 201	Ɔ 217	Ú 233	¨ 249
A	è 138	Ü 154	¬ 170	‖ 186	⊥ 202	Ɔ 218	Û 234	· 250
B	ï 139	ø 155	½ 171	¶ 187	⊥ 203	■ 219	Ù 235	¹ 251
C	î 140	£ 156	¼ 172	‡ 188	‡ 204	■ 220	Ý 236	³ 252
D	ì 141	Ø 157	ı 173	¢ 189	= 205	ı 221	Ý 237	² 253
E	Ä 142	× 158	« 174	¥ 190	‡ 206	Ï 222	- 238	■ 254
F	Å 143	f 159	» 175	Ɔ 191	α 207	■ 223	' 239	SP 255

HEX	8	9	A	B	C	D	E	F
0	Ç 128	É 144	á 160	 176	L 192	⌌ 208	α 224	≡ 240
1	ü 129	À 145	í 161	 177	⊥ 193	⌌ 209	β 225	± 241
2	é 130	È 146	ó 162	 178	⊥ 194	π 210	Γ 226	≥ 242
3	â 131	ô 147	ú 163	 179	⊥ 195	⌌ 211	π 227	≤ 243
4	ã 132	õ 148	ñ 164	⊥ 180	— 196	⌌ 212	Σ 228	∫ 244
5	à 133	ò 149	Ñ 165	⊥ 181	⊥ 197	⌌ 213	σ 229	∫ 245
6	Á 134	Ú 150	ª 166	⌌ 182	⌌ 198	π 214	μ 230	÷ 246
7	ç 135	ù 151	º 167	π 183	⌌ 199	⌌ 215	τ 231	≈ 247
8	ê 136	Ì 152	¿ 168	⌌ 184	⌌ 200	⌌ 216	Φ 232	° 248
9	Ê 137	Õ 153	Ò 169	⌌ 185	⌌ 201	⌌ 217	Θ 233	• 249
A	è 138	Ü 154	¬ 170	⌌ 186	⌌ 202	⌌ 218	Ω 234	· 250
B	Í 139	ç 155	½ 171	⌌ 187	⌌ 203	 219	ð 235	√ 251
C	Ô 140	£ 156	¼ 172	⌌ 188	⌌ 204	 220	∞ 236	ⁿ 252
D	ì 141	Ù 157	ì 173	⌌ 189	= 205	 221	Φ 237	² 253
E	Ã 142	Pt 158	« 174	⌌ 190	⌌ 206	 222	ε 238	■ 254
F	Â 143	Ó 159	» 175	⌌ 191	⌌ 207	 223	∩ 239	SP 255

Page 4 (PC863: Canadian-French)

HEX	8	9	A	B	C	D	E	F
0	Ç 128	É 144	ı 160	☐ 176	Ł 192	⌌ 208	α 224	≡ 240
1	ü 129	È 145	´ 161	☐ 177	⊥ 193	⌌ 209	β 225	± 241
2	é 130	Ê 146	ó 162	☐ 178	⊤ 194	⌌ 210	Γ 226	≥ 242
3	â 131	ô 147	ú 163	 179	⊥ 195	⌌ 211	π 227	≤ 243
4	Â 132	Ë 148	¨ 164	⊥ 180	— 196	⌌ 212	Σ 228	∫ 244
5	à 133	Ï 149	˙ 165	⊥ 181	⊥ 197	ƒ 213	σ 229	∫ 245
6	¶ 134	û 150	³ 166	⌌ 182	ƒ 198	π 214	μ 230	÷ 246
7	ç 135	ù 151	— 167	⌌ 183	⌌ 199	⌌ 215	τ 231	≈ 247
8	ê 136	α 152	Î 168	ƒ 184	⌌ 200	⊥ 216	Φ 232	° 248
9	ë 137	Ô 153	ƒ 169	⌌ 185	ƒ 201	⊥ 217	Θ 233	• 249
A	è 138	Û 154	¬ 170	⌌ 186	⌌ 202	ƒ 218	Ω 234	· 250
B	ï 139	ø 155	½ 171	⌌ 187	⌌ 203	■ 219	δ 235	√ 251
C	î 140	£ 156	¼ 172	⌌ 188	⌌ 204	■ 220	∞ 236	ⁿ 252
D	= 141	Û 157	¾ 173	⌌ 189	= 205	■ 221	Φ 237	² 253
E	À 142	Û 158	« 174	⌌ 190	⌌ 206	■ 222	ε 238	■ 254
F	§ 143	f 159	» 175	⌌ 191	⌌ 207	■ 223	∩ 239	SP 255

HEX	8	9	A	B	C	D	E	F
0	Ç 128	É 144	á 160	 176	L 192	⌌ 208	α 224	≡ 240
1	ü 129	æ 145	í 161	 177	⊥ 193	⌑ 209	β 225	± 241
2	é 130	Æ 146	ó 162	 178	⊤ 194	⌒ 210	Γ 226	≥ 242
3	â 131	ô 147	ú 163	 179	⊥ 195	⌌ 211	π 227	≤ 243
4	ä 132	ö 148	ñ 164	⊥ 180	— 196	⌑ 212	Σ 228	∫ 244
5	à 133	ò 149	Ñ 165	⊥ 181	⊥ 197	⌑ 213	σ 229	∫ 245
6	å 134	û 150	ä 166	⌑ 182	⌑ 198	⌑ 214	μ 230	÷ 246
7	ç 135	ù 151	º 167	⌑ 183	⌑ 199	⌑ 215	τ 231	≈ 247
8	ê 136	ÿ 152	¿ 168	⌑ 184	⌑ 200	⌑ 216	Φ 232	° 248
9	ë 137	Ö 153	Г 169	⌑ 185	Г 201	⌑ 217	Θ 233	• 249
A	è 138	Ü 154	Г 170	⌑ 186	⌑ 202	Г 218	Ω 234	• 250
B	ï 139	ø 155	½ 171	⌑ 187	⌑ 203	 219	δ 235	√ 251
C	î 140	£ 156	¼ 172	⌑ 188	⌑ 204	 220	∞ 236	ⁿ 252
D	ì 141	Ø 157	ı 173	⌑ 189	= 205	 221	Φ 237	² 253
E	Ä 142	Pt 158	« 174	⌑ 190	⌑ 206	 222	ε 238	■ 254
F	Å 143	f 159	α 175	⌑ 191	⌑ 207	 223	∩ 239	SP 255









Page 11 (PC851: Greek)

HEX	8	9	A	B	C	D	E	F
0	Ç 128	Ï 144	ï 160	☼ 176	Ł 192	Ƨ 208	ζ 224	- 240
1	ü 129	SP 145	ï 161	☼ 177	⊥ 193	Υ 209	η 225	± 241
2	é 130	Ŏ 146	ó 162	☼ 178	⊥ 194	Φ 210	θ 226	υ 242
3	â 131	ô 147	ú 163	 179	† 195	Χ 211	ι 227	Φ 243
4	ä 132	ö 148	Α 164	† 180	- 196	Ψ 212	κ 228	Χ 244
5	à 133	Υ 149	Β 165	Κ 181	† 197	Ω 213	λ 229	§ 245
6	À 134	Û 150	Γ 166	Λ 182	Π 198	α 214	μ 230	Ψ 246
7	ç 135	ù 151	Δ 167	Μ 183	Ρ 199	β 215	ν 231	ˆ 247
8	ê 136	Ω 152	Ε 168	Ν 184	ℒ 200	γ 216	ξ 232	° 248
9	ë 137	Ö 153	Ζ 169	‡ 185	℞ 201	∟ 217	ο 233	¨ 249
A	è 138	Ü 154	Η 170	∥ 186	⊥ 202	Γ 218	π 234	ω 250
B	ï 139	ά 155	½ 171	‡ 187	⊥ 203	■ 219	ρ 235	Û 251
C	î 140	£ 156	Θ 172	‡ 188	‡ 204	■ 220	σ 236	Û 252
D	É 141	έ 157	Ι 173	≡ 189	= 205	δ 221	ς 237	ώ 253
E	Ä 142	ή 158	« 174	Ο 190	‡ 206	ε 222	τ 238	■ 254
F	Ḥ 143	ι 159	» 175	γ 191	Σ 207	■ 223	' 239	SP 255

HEX	8	9	A	B	C	D	E	F
0	Ç 128	É 144	á 160	☐ 176	L 192	SP 208	Ó 224	- 240
1	ü 129	ć 145	í 161	☐ 177	⊥ 193	SP 209	β 225	SP 241
2	é 130	Ĉ 146	ó 162	☐ 178	⊥ 194	Ê 210	Ô 226	ł 242
3	â 131	ô 147	ú 163	 179	⊥ 195	Ë 211	Ò 227	ʰ 243
4	ä 132	ö 148	ñ 164	⊥ 180	- 196	È 212	Ĝ 228	˘ 244
5	à 133	ò 149	Ñ 165	Á 181	⊥ 197	ı 213	ğ 229	§ 245
6	ĉ 134	û 150	Ĝ 166	Â 182	Ŝ 198	Í 214	μ 230	÷ 246
7	ç 135	ù 151	ğ 167	À 183	ŝ 199	Î 215	℥ 231	˙ 247
8	ê 136	İ 152	Ĥ 168	Ş 184	℥ 200	İ 216	ħ 232	° 248
9	ë 137	Ö 153	ĥ 169	‡ 185	℥ 201	Ј 217	Ú 233	ˆ 249
A	è 138	Ü 154	SP 170	 186	⊥ 202	Г 218	Û 234	˙ 250
B	ï 139	ĝ 155	½ 171	‡ 187	⊥ 203	■ 219	Ù 235	SP 251
C	î 140	£ 156	Ĵ 172	‡ 188	⊥ 204	■ 220	Û 236	³ 252
D	ì 141	Ĝ 157	ş 173	Ž 189	= 205	SP 221	ů 237	² 253
E	Ä 142	× 158	« 174	ž 190	‡ 206	Ì 222	· 238	■ 254
F	Ĉ 143	ĵ 159	» 175	⊥ 191	α 207	■ 223	´ 239	SP 255

Page 13 (PC857: Turkish)

HEX	8	9	A	B	C	D	E	F
0	Ç 128	É 144	á 160	☐ 176	Ł 192	◌ 208	Ó 224	- 240
1	ü 129	æ 145	í 161	☐ 177	⊥ 193	ª 209	β 225	± 241
2	é 130	Æ 146	ó 162	☐ 178	⊥ 194	Ê 210	Ô 226	SP 242
3	â 131	ô 147	ú 163	 179	⊥ 195	Ë 211	Ò 227	¾ 243
4	ä 132	ö 148	ñ 164	⊥ 180	- 196	È 212	õ 228	¶ 244
5	à 133	ò 149	Ñ 165	Á 181	† 197	€ 213	Õ 229	§ 245
6	å 134	û 150	Ǧ 166	Â 182	ã 198	Í 214	μ 230	÷ 246
7	ç 135	ù 151	ǧ 167	À 183	Ã 199	Î 215	SP 231	˘ 247
8	ê 136	Ï 152	¿ 168	© 184	ℒ 200	Ï 216	× 232	° 248
9	ë 137	Ö 153	® 169	‡ 185	℞ 201	Ɔ 217	Ú 233	¨ 249
A	è 138	Ü 154	¬ 170	‖ 186	⊥ 202	Ɔ 218	Û 234	· 250
B	ï 139	ø 155	½ 171	¶ 187	⊥ 203	■ 219	Ù 235	¹ 251
C	î 140	£ 156	¼ 172	‡ 188	‡ 204	■ 220	ì 236	³ 252
D	ı 141	Ø 157	ı 173	¢ 189	= 205	ı 221	ÿ 237	² 253
E	Ä 142	Ş 158	« 174	¥ 190	‡ 206	Ï 222	- 238	■ 254
F	Å 143	ş 159	» 175	Ɔ 191	α 207	■ 223	' 239	SP 255

HEX	8	9	A	B	C	D	E	F
0	A 128	P 144	ι 160	 176	L 192	⊥ 208	ω 224	Ω 240
1	B 129	Σ 145	κ 161	 177	⊥ 193	⊥ 209	ά 225	± 241
2	Γ 130	Τ 146	λ 162	 178	Τ 194	Π 210	έ 226	≥ 242
3	Δ 131	Υ 147	μ 163	 179	⊥ 195	⊥ 211	ή 227	≤ 243
4	E 132	Φ 148	ν 164	⊥ 180	- 196	⊥ 212	ι 228	ï 244
5	Z 133	X 149	ξ 165	⊥ 181	⊥ 197	F 213	ι 229	ÿ 245
6	H 134	Ψ 150	ο 166	⊥ 182	⊥ 198	Π 214	ό 230	÷ 246
7	Θ 135	Ω 151	π 167	Π 183	⊥ 199	⊥ 215	ύ 231	≈ 247
8	I 136	α 152	ρ 168	⊥ 184	⊥ 200	⊥ 216	ü 232	° 248
9	K 137	β 153	σ 169	⊥ 185	⊥ 201	⊥ 217	ώ 233	• 249
A	Λ 138	γ 154	ς 170	⊥ 186	⊥ 202	⊥ 218	Α 234	· 250
B	M 139	δ 155	τ 171	⊥ 187	⊥ 203	 219	Έ 235	√ 251
C	N 140	ε 156	υ 172	⊥ 188	⊥ 204	 220	Ή 236	ⁿ 252
D	≡ 141	ζ 157	φ 173	⊥ 189	= 205	 221	Ί 237	² 253
E	O 142	η 158	χ 174	⊥ 190	⊥ 206	 222	Ό 238	■ 254
F	Π 143	θ 159	ψ 175	⊥ 191	⊥ 207	 223	Ύ 239	SP 255

Page 15 (ISO8859-7: Greek)

HEX	8	9	A	B	C	D	E	F
0	SP 128	SP 144	SP 160	° 176	ï 192	Π 208	Û 224	π 240
1	SP 129	SP 145	‘ 161	± 177	Α 193	Ρ 209	α 225	ρ 241
2	SP 130	SP 146	’ 162	² 178	Β 194	Σ 210	β 226	ς 242
3	SP 131	SP 147	£ 163	³ 179	Γ 195	Τ 211	γ 227	σ 243
4	SP 132	SP 148	€ 164	´ 180	Δ 196	Υ 212	δ 228	τ 244
5	SP 133	SP 149	Ɔρ 165	ˆ 181	Ε 197	Φ 213	ε 229	υ 245
6	SP 134	SP 150	ι 166	Α 182	Ζ 198	Φ 214	ζ 230	φ 246
7	SP 135	SP 151	§ 167	• 183	Η 199	Χ 215	η 231	χ 247
8	SP 136	SP 152	¨ 168	Έ 184	Θ 200	Ψ 216	θ 232	ψ 248
9	SP 137	SP 153	© 169	Ή 185	Ι 201	Ω 217	ι 233	ω 249
A	SP 138	SP 154	˘ 170	Ί 186	Κ 202	Ϊ 218	κ 234	ϊ 250
B	SP 139	SP 155	« 171	» 187	Λ 203	Ϋ 219	λ 235	ϋ 251
C	SP 140	SP 156	¬ 172	Ό 188	Μ 204	ά 220	μ 236	ό 252
D	SP 141	SP 157	- 173	½ 189	Ν 205	έ 221	ν 237	ύ 253
E	SP 142	SP 158	SP 174	Υ 190	Ξ 206	ή 222	ξ 238	ώ 254
F	SP 143	SP 159	— 175	Ω 191	Ο 207	ι 223	ο 239	SP 255

HEX	8	9	A	B	C	D	E	F
0	€ 128	SP 144	SP 160	° 176	À 192	Đ 208	à 224	đ 240
1	SP 129	' 145	ı 161	± 177	Á 193	Ñ 209	á 225	ñ 241
2	, 130	' 146	ç 162	² 178	Â 194	Ò 210	â 226	ò 242
3	f 131	“ 147	£ 163	³ 179	Ã 195	Ó 211	ã 227	ó 243
4	” 132	” 148	¤ 164	' 180	Ä 196	Ô 212	ä 228	ô 244
5	... 133	• 149	¥ 165	µ 181	Å 197	Õ 213	å 229	õ 245
6	† 134	– 150	ı 166	¶ 182	Æ 198	Ö 214	æ 230	ö 246
7	‡ 135	— 151	§ 167	· 183	Ç 199	× 215	ç 231	÷ 247
8	^ 136	~ 152	¨ 168	¸ 184	È 200	Ø 216	è 232	ø 248
9	‰ 137	™ 153	© 169	¹ 185	É 201	Ù 217	é 233	ù 249
A	Š 138	š 154	ª 170	º 186	Ê 202	Ú 218	ê 234	ú 250
B	‹ 139	› 155	« 171	» 187	Ë 203	Û 219	ë 235	û 251
C	Œ 140	œ 156	¬ 172	¼ 188	Ì 204	Ü 220	ì 236	ü 252
D	SP 141	SP 157	- 173	½ 189	Í 205	Ý 221	í 237	ý 253
E	Ž 142	ž 158	® 174	¾ 190	Î 206	Þ 222	î 238	þ 254
F	SP 143	ÿ 159	– 175	¿ 191	Ï 207	ß 223	ï 239	ÿ 255

Page 17 (PC866: Cyrillic #2)

HEX	8	9	A	B	C	D	E	F
0	А 128	Р 144	а 160	▒ 176	Л 192	л 208	р 224	ё 240
1	Б 129	С 145	б 161	▓ 177	┘ 193	т 209	с 225	ё 241
2	В 130	Т 146	в 162	█ 178	т 194	т 210	т 226	Є 242
3	Г 131	У 147	г 163	 179	┘ 195	л 211	у 227	є 243
4	Д 132	Ф 148	д 164	┘ 180	— 196	л 212	ф 228	ï 244
5	Е 133	Х 149	е 165	┘ 181	┘ 197	ф 213	х 229	ï 245
6	Ж 134	Ц 150	ж 166	▒▒ 182	ф 198	г 214	ц 230	ÿ 246
7	З 135	Ч 151	з 167	т 183	т 199	т 215	ч 231	ÿ 247
8	И 136	Ш 152	и 168	т 184	л 200	т 216	ш 232	° 248
9	Й 137	Щ 153	й 169	т 185	г 201	┘ 217	щ 233	• 249
A	К 138	Ъ 154	к 170	▒▒ 186	л 202	г 218	ъ 234	· 250
B	Л 139	Ы 155	л 171	т 187	т 203	█ 219	ы 235	√ 251
C	М 140	Ь 156	м 172	л 188	т 204	█ 220	ь 236	№ 252
D	Н 141	Э 157	н 173	л 189	= 205	█ 221	э 237	¤ 253
E	О 142	Ю 158	о 174	┘ 190	т 206	█ 222	ю 238	■ 254
F	П 143	Я 159	п 175	┘ 191	л 207	█ 223	я 239	SP 255

HEX	8	9	A	B	C	D	E	F
0	Ç 128	É 144	á 160	☐ 176	Ł 192	đ 208	Ó 224	- 240
1	ü 129	Í 145	í 161	☐ 177	⊥ 193	Đ 209	β 225	“ 241
2	é 130	Í 146	ó 162	☐ 178	⊥ 194	Ď 210	Ô 226	˘ 242
3	â 131	ô 147	ú 163	 179	† 195	Ě 211	Ń 227	˘ 243
4	ä 132	ö 148	Ą 164	† 180	- 196	ď 212	ń 228	˘ 244
5	û 133	Ĺ 149	ą 165	Á 181	† 197	Ň 213	ň 229	§ 245
6	ć 134	ĩ 150	ž 166	Â 182	Ă 198	Í 214	Š 230	÷ 246
7	ç 135	Ś 151	ž 167	Ě 183	ă 199	Î 215	š 231	˘ 247
8	ł 136	ś 152	Ę 168	Ş 184	Ł 200	ě 216	Ŕ 232	° 248
9	ë 137	Ö 153	ę 169	‡ 185	ƒ 201	Ɔ 217	Ú 233	“ 249
A	Ő 138	Ü 154	SP 170	‡ 186	⊥ 202	ƒ 218	ŕ 234	• 250
B	ő 139	Ť 155	ž 171	‡ 187	⊥ 203	■ 219	Ů 235	ů 251
C	î 140	ť 156	Č 172	‡ 188	‡ 204	■ 220	ý 236	Ř 252
D	Ž 141	ł 157	ş 173	Ž 189	= 205	Ť 221	Ý 237	ř 253
E	Ä 142	× 158	« 174	ž 190	‡ 206	Ů 222	ţ 238	■ 254
F	Ć 143	č 159	» 175	ŧ 191	α 207	■ 223	’ 239	SP 255

Page 19 (PC858: Euro)

HEX	8	9	A	B	C	D	E	F
0	Ç 128	É 144	á 160	☐ 176	Ł 192	đ 208	Ó 224	- 240
1	ü 129	æ 145	í 161	☐ 177	⊥ 193	Đ 209	β 225	± 241
2	é 130	Æ 146	ó 162	☐ 178	⊥ 194	Ê 210	Ô 226	= 242
3	â 131	ô 147	ú 163	 179	† 195	Ë 211	Ò 227	¾ 243
4	ä 132	ö 148	ñ 164	‡ 180	— 196	È 212	õ 228	¶ 244
5	à 133	ò 149	Ñ 165	Á 181	† 197	€ 213	Õ 229	§ 245
6	å 134	û 150	ä 166	Â 182	ã 198	Í 214	μ 230	÷ 246
7	ç 135	ù 151	º 167	À 183	Ã 199	Î 215	þ 231	˘ 247
8	ê 136	ÿ 152	¿ 168	© 184	℔ 200	Ï 216	ƒ 232	° 248
9	ë 137	Ö 153	® 169	‡ 185	℔ 201	⋈ 217	Ú 233	¨ 249
A	è 138	Ü 154	¬ 170	 186	⊥ 202	ƒ 218	Û 234	· 250
B	ï 139	ø 155	½ 171	¶ 187	⊥ 203	■ 219	Ù 235	¹ 251
C	î 140	£ 156	¼ 172	¶ 188	⊥ 204	■ 220	Ý 236	³ 252
D	ì 141	Ø 157	ì 173	¢ 189	= 205	ì 221	Ý 237	² 253
E	Ä 142	× 158	« 174	¥ 190	⊥ 206	Ï 222	— 238	■ 254
F	Å 143	f 159	» 175	‡ 191	α 207	■ 223	' 239	SP 255

HEX	8	9	A	B	C	D	E	F
0	┌ 128	○ 144	SP 160	ฅ 176	ย 192	เ 208	' 224	๓ 240
1	┐ 129	๑ 145	ก 161	ณ 177	ร 193	แ 209	๕ 225	๔+ 241
2	└ 130	๒ 146	ข 162	ด 178	ฤ 194	โ 210	๖ 226	๕+ 242
3	┘ 131	๓ 147	ค 163	ต 179	ล 195	ใ 211	๗ 227	๖+ 243
4	┌ 132	๔ 148	ฅ 164	ถ 180	ว 196	ใ 212	๘ 228	๖+ 244
5	┐ 133	๕ 149	ง 165	ท 181	ศ 197	ๆ 213	๙ 229	๗+ 245
6	└ 134	๖ 150	จ 166	ธ 182	ษ 198	ๆ 214	๑๐ 230	๗+ 246
7	┘ 135	๗ 151	ฉ 167	น 183	ส 199	' 215	๑๑ 231	๘+ 247
8	┌ 136	๘ 152	ช 168	บ 184	ห 200	๑๒ 216	๑๒ 232	๘+ 248
9	┐ 137	๙ 153	ฅ 169	ป 185	ฬ 201	๑๓ 217	๑๓ 233	๙+ 249
A	└ 138	๑๐ 154	ฅ 170	ผ 186	อ 202	๑๔ 218	๑๔ 234	๑๐+ 250
B	┘ 139	๑๑ 155	ฅ 171	ฝ 187	ฮ 203	๑๕ 219	๑๕ 235	๑๑+ 251
C	← 140	โ 156	ฅ 172	พ 188	๑๖ 204	๑๖ 220	๑๖ 236	๑๒+ 252
D	↑ 141	ใ 157	ฅ 173	ฟ 189	ภ 205	๑๗ 221	๑๗ 237	๑๓+ 253
E	→ 142	ใ 158	ฅ 174	ภ 190	ภ 206	๑๘ 222	๑๘ 238	๑๔+ 254
F	↓ 143	เ 159	ท 175	ม 191	ำ 207	๑๙ 223	๑๙ 239	SP 255

Page 21 (TIS11: Thai)

HEX	8	9	A	B	C	D	E	F
0	๐ 128	๑ 144	๒ 160	๓ 176	๔ 192	๕ 208	๖ 224	๗ 240
1	๘ 129	๙ 145	๐ 161	๑ 177	๒ 193	๓ 209	๔ 225	๕ 241
2	๖ 130	๗ 146	๘ 162	๙ 178	๐ 194	๑ 210	๒ 226	๓ 242
3	๘ 131	๙ 147	๐ 163	๑ 179	๒ 195	๓ 211	๔ 227	๕ 243
4	๐ 132	๑ 148	๒ 164	๓ 180	๔ 196	๕ 212	๖ 228	๗ 244
5	๑ 133	๒ 149	๓ 165	๔ 181	๕ 197	๖ 213	๗ 229	๘ 245
6	๒ 134	๓ 150	๔ 166	๕ 182	๖ 198	๗ 214	๘ 230	๙ 246
7	๓ 135	๔ 151	๕ 167	๖ 183	๗ 199	๘ 215	๙ 231	๐ 247
8	๔ 136	๕ 152	๖ 168	๗ 184	๘ 200	๙ 216	๐ 232	๑ 248
9	๕ 137	๖ 153	๗ 169	๘ 185	๙ 201	๐ 217	๑ 233	๒ 249
A	๖ 138	๗ 154	๘ 170	๙ 186	๐ 202	๑ 218	๒ 234	๓ 250
B	๗ 139	๘ 155	๙ 171	๐ 187	๑ 203	๒ 219	๓ 235	๔ 251
C	๘ 140	๙ 156	๐ 172	๑ 188	๒ 204	๓ 220	๔ 236	๕ 252
D	๙ 141	๐ 157	๑ 173	๒ 189	๓ 205	๔ 221	๕ 237	๖ 253
E	๐ 142	๑ 158	๒ 174	๓ 190	๔ 206	๕ 222	๖ 238	๗ 254
F	๑ 143	๒ 159	๓ 175	๔ 191	๕ 207	๖ 223	๗ 239	๘ 255









HEX	8	9	A	B	C	D	E	F
0	┌ 128	┐ 144	SP 160	๒ 176	๓ 192	๔ 208	๕ 224	๖ 240
1	└ 129	┑ 145	ก 161	ข 177	ฃ 193	๔ 209	๕ 225	๖ 241
2	┌ 130	๔ 146	ข 162	ฃ 178	๔ 194	๕ 210	๖ 226	๗ 242
3	└ 131	๕ 147	ข 163	ฃ 179	๔ 195	๕ 211	๖ 227	๗ 243
4	┌ 132	๖ 148	ค 164	ด 180	๔ 196	๕ 212	๖ 228	๗ 244
5	└ 133	๗ 149	ค 165	ด 181	๔ 197	๕ 213	๖ 229	๗ 245
6	┌ 134	๘ 150	ฃ 166	๔ 182	๕ 198	๖ 214	๗ 230	๘ 246
7	└ 135	๙ 151	ง 167	๗ 183	๘ 199	๙ 215	๑๐ 231	๑๑ 247
8	┌ 136	๑๐ 152	จ 168	๘ 184	๑๐ 200	๑๑ 216	๑๒ 232	๑๓ 248
9	└ 137	๑๑ 153	ฉ 169	๘ 185	๑๐ 201	๑๑ 217	๑๒ 233	๑๓ 249
A	┌ 138	๑๒ 154	ช 170	๘ 186	๑๐ 202	๑๑ 218	๑๒ 234	๑๓ 250
B	█ 139	๑๓ 155	ช 171	๘ 187	๑๐ 203	๑๑ 219	๑๒ 235	๑๓ 251
C	← 140	๑๔ 156	ฃ 172	๘ 188	๑๐ 204	๑๑ 220	๑๒ 236	๑๓ 252
D	↑ 141	๑๕ 157	ฃ 173	๘ 189	๑๐ 205	๑๑ 221	๑๒ 237	๑๓ 253
E	→ 142	๑๖ 158	ฃ 174	๘ 190	๑๐ 206	๑๑ 222	๑๒ 238	๑๓ 254
F	↓ 143	๑๗ 159	ฃ 175	๘ 191	๑๐ 207	๑๑ 223	๑๒ 239	SP 255

Page 30 (TCVN-3: Vietnamese)

HEX	8	9	A	B	C	D	E	F
0	SP 128	SP 144	SP 160	SP 176	SP 192	é 208	SP 224	SP 240
1	SP 129	SP 145	SP 161	SP 177	SP 193	ẹ 209	ỏ 225	ủ 241
2	SP 130	SP 146	SP 162	SP 178	SP 194	ề 210	ỗ 226	ũ 242
3	SP 131	SP 147	SP 163	SP 179	SP 195	ễ 211	ó 227	ú 243
4	SP 132	SP 148	SP 164	SP 180	SP 196	ễ 212	ọ 228	ụ 244
5	SP 133	SP 149	SP 165	à 181	SP 197	ễ 213	ồ 229	ừ 245
6	SP 134	SP 150	SP 166	ả 182	ặ 198	ệ 214	ổ 230	ừ 246
7	SP 135	SP 151	SP 167	ã 183	ầ 199	ì 215	ỗ 231	ừ 247
8	SP 136	SP 152	ã 168	á 184	ã 200	ỉ 216	ổ 232	ừ 248
9	SP 137	SP 153	â 169	ạ 185	ã 201	SP 217	ộ 233	ự 249
A	SP 138	SP 154	ê 170	SP 186	ã 202	SP 218	ờ 234	ỳ 250
B	SP 139	SP 155	ô 171	ã 187	ậ 203	SP 219	ở 235	ỳ 251
C	SP 140	SP 156	ơ 172	ã 188	è 204	ĩ 220	ỡ 236	ỳ 252
D	SP 141	SP 157	ư 173	ã 189	SP 205	í 221	ớ 237	ỳ 253
E	SP 142	SP 158	đ 174	ã 190	ẻ 206	ị 222	ợ 238	ỵ 254
F	SP 143	SP 159	SP 175	SP 191	ễ 207	ò 223	ù 239	SP 255

HEX	8	9	A	B	C	D	E	F
0	SP 128	SP 144	SP 160	SP 176	SP 192	É 208	SP 224	SP 240
1	SP 129	SP 145	Ă 161	SP 177	SP 193	Ě 209	Ỗ 225	Ủ 241
2	SP 130	SP 146	Â 162	SP 178	SP 194	Ê 210	Ỗ 226	Û 242
3	SP 131	SP 147	SP 163	SP 179	SP 195	Ë 211	Ó 227	Ú 243
4	SP 132	SP 148	SP 164	SP 180	SP 196	Ě 212	Ọ 228	Ụ 244
5	SP 133	SP 149	SP 165	À 181	SP 197	Ë 213	Ồ 229	Ừ 245
6	SP 134	SP 150	SP 166	À 182	Ạ 198	Ě 214	Ỗ 230	Ừ 246
7	SP 135	SP 151	Đ 167	Ă 183	Â 199	ì 215	Ỗ 231	Ừ 247
8	SP 136	SP 152	SP 168	Á 184	Ã 200	ĩ 216	Ỗ 232	Ừ 248
9	SP 137	SP 153	SP 169	Ạ 185	Ã 201	SP 217	Ỗ 233	Ừ 249
A	SP 138	SP 154	Ê 170	SP 186	Ã 202	SP 218	Ờ 234	Ỡ 250
B	SP 139	SP 155	Ô 171	Ă 187	Ạ 203	SP 219	Ỗ 235	Ỡ 251
C	SP 140	SP 156	Ơ 172	Ă 188	È 204	ĩ 220	Ỗ 236	Ỡ 252
D	SP 141	SP 157	Ừ 173	Ă 189	SP 205	í 221	Ớ 237	Ỡ 253
E	SP 142	SP 158	SP 174	Á 190	È 206	! 222	Ớ 238	Ỡ 254
F	SP 143	SP 159	SP 175	SP 191	Ë 207	Ò 223	Ừ 239	SP 255

Page 32 (PC720: Arabic)

HEX	8	9	A	B	C	D	E	F
0	SP 128	SP 144	ب 160	 176	ل 192	ل 208	ن 224	م 240
1	SP 129	ر 145	ة 161	 177	ط 193	ف 209	ظ 225	ن 241
2	é 130	و 146	ت 162	 178	ث 194	ط 210	ظ 226	ن 242
3	â 131	ô 147	ث 163	 179	ث 195	ل 211	ع 227	ن 243
4	SP 132	خ 148	ج 164	ح 180	- 196	ع 212	غ 228	ن 244
5	à 133	- 149	ح 165	ح 181	ث 197	ف 213	ف 229	ن 245
6	SP 134	û 150	خ 166	ل 182	ف 198	ط 214	م 230	ن 246
7	ç 135	ù 151	د 167	ط 183	ث 199	ث 215	ق 231	ن 247
8	ê 136	ء 152	ذ 168	ك 184	ل 200	ث 216	ك 232	و 248
9	ë 137	أ 153	ر 169	ل 185	ط 201	ل 217	ل 233	و 249
A	è 138	أ 154	ز 170	ل 186	ل 202	ط 218	م 234	و 250
B	ï 139	ؤ 155	س 171	ط 187	ط 203	 219	ن 235	ن 251
C	î 140	£ 156	ش 172	ك 188	ل 204	 220	ه 236	ن 252
D	SP 141	إ 157	س 173	ل 189	= 205	 221	و 237	ن 253
E	SP 142	ئ 158	« 174	ك 190	ث 206	 222	ي 238	ن 254
F	SP 143	أ 159	» 175	ك 191	ل 207	 223	ي 239	SP 255

HEX	8	9	A	B	C	D	E	F
0	Ć 128	É 144	Ā 160	⦿ 176	Ł 192	ą 208	Ó 224	- 240
1	ü 129	æ 145	Ī 161	⦿ 177	Ł 193	č 209	ß 225	± 241
2	é 130	Æ 146	ó 162	⦿ 178	Ṭ 194	ę 210	Ō 226	“ 242
3	ā 131	ō 147	Ž 163	 179	Ṭ 195	è 211	Ń 227	¾ 243
4	ä 132	ö 148	ž 164	† 180	- 196	ì 212	õ 228	¶ 244
5	ǵ 133	Ǵ 149	ž 165	Å 181	† 197	š 213	Õ 229	§ 245
6	å 134	ϕ 150	” 166	Č 182	Ū 198	ų 214	μ 230	÷ 246
7	ć 135	Ś 151	¡ 167	Ę 183	Ū 199	ū 215	ń 231	” 247
8	ł 136	ś 152	© 168	É 184	Ł 200	ż 216	Ų 232	° 248
9	ē 137	Ö 153	® 169	‡ 185	Ŧ 201	ǰ 217	ķ 233	· 249
A	Ŕ 138	Ü 154	¬ 170	‡ 186	Ł 202	Ŧ 218	ķ 234	· 250
B	ŗ 139	ø 155	½ 171	‡ 187	Ŧ 203	■ 219	¡ 235	¹ 251
C	ī 140	£ 156	¼ 172	‡ 188	Ŧ 204	■ 220	ŋ 236	³ 252
D	Ž 141	Ø 157	Ł 173	ł 189	= 205	■ 221	Ě 237	² 253
E	Ä 142	× 158	« 174	Š 190	‡ 206	■ 222	Ņ 238	■ 254
F	Å 143	α 159	» 175	Ṭ 191	Ž 207	■ 223	’ 239	SP 255

Page 34 (PC855: Cyrillic)

HEX	8	9	A	B	C	D	E	F
0	ђ 128	љ 144	а 160	▒ 176	Љ 192	л 208	Я 224	- 240
1	Ђ 129	Љ 145	А 161	▒ 177	Љ 193	Л 209	Р 225	Ы 241
2	ѓ 130	њ 146	б 162	▒ 178	Т 194	М 210	Р 226	Ы 242
3	Ѓ 131	Њ 147	Б 163	 179	Ћ 195	М 211	С 227	З 243
4	ё 132	ђ 148	ц 164	† 180	— 196	Н 212	С 228	З 244
5	Ё 133	Ђ 149	Ц 165	х 181	† 197	Н 213	Т 229	Ш 245
6	е 134	ќ 150	д 166	Х 182	К 198	О 214	Т 230	Ш 246
7	Е 135	Ќ 151	Д 167	И 183	К 199	О 215	У 231	Э 247
8	ѕ 136	ђ 152	е 168	И 184	Љ 200	П 216	У 232	Э 248
9	Ѕ 137	Ђ 153	Е 169	Ѓ 185	Ѓ 201	Ѓ 217	Ж 233	Щ 249
A	і 138	џ 154	ф 170	 186	Љ 202	Г 218	Ж 234	Щ 250
B	І 139	џ 155	Ф 171	џ 187	џ 203	■ 219	В 235	Ч 251
C	ї 140	ю 156	Г 172	Ѓ 188	џ 204	■ 220	В 236	Ч 252
D	İ 141	Ю 157	Г 173	Й 189	= 205	П 221	Ь 237	§ 253
E	ј 142	ѣ 158	« 174	Й 190	џ 206	Я 222	Ь 238	■ 254
F	Ј 143	ѣ 159	» 175	Г 191	џ 207	■ 223	№ 239	SP 255

HEX	8	9	A	B	C	D	E	F
0	Ç 128	É 144	á 160	☐ 176	Ł 192	⌌ 208	α 224	≡ 240
1	ü 129	æ 145	í 161	☐ 177	⌞ 193	⌘ 209	ß 225	± 241
2	é 130	Æ 146	ó 162	☐ 178	⌟ 194	⌡ 210	Γ 226	≥ 242
3	â 131	ô 147	ú 163	 179	⌠ 195	⌢ 211	π 227	≤ 243
4	ä 132	ö 148	Á 164	⌡ 180	– 196	⌣ 212	Σ 228	∫ 244
5	à 133	þ 149	Í 165	⌢ 181	† 197	⌤ 213	σ 229	∫ 245
6	å 134	û 150	Ó 166	⌣ 182	‡ 198	⌥ 214	μ 230	÷ 246
7	ç 135	Ý 151	Ú 167	⌤ 183	⌥ 199	⌦ 215	τ 231	≈ 247
8	ê 136	ý 152	ı 168	⌦ 184	⌧ 200	⌧ 216	Φ 232	° 248
9	ë 137	Ö 153	ƒ 169	⌧ 185	⌨ 201	⌨ 217	Θ 233	· 249
A	è 138	Ü 154	ƒ 170	⌨ 186	〈 202	〈 218	Ω 234	· 250
B	Ð 139	ø 155	½ 171	〈 187	〉 203	■ 219	δ 235	√ 251
C	ð 140	£ 156	¼ 172	〉 188	⌫ 204	■ 220	∞ 236	n 252
D	þ 141	Ø 157	i 173	⌫ 189	= 205	■ 221	φ 237	z 253
E	Ä 142	Pt 158	« 174	⌫ 190	⌬ 206	■ 222	ε 238	■ 254
F	Å 143	f 159	» 175	⌬ 191	⌭ 207	■ 223	∩ 239	SP 255

Page 36 (PC862: Hebrew)

HEX	8	9	A	B	C	D	E	F
0	כ 128	ג 144	א 160	⋯ 176	ל 192	⌚ 208	α 224	≡ 240
1	כּ 129	גּ 145	אׁ 161	⋯ 177	לׁ 193	⌚ 209	β 225	± 241
2	כׁ 130	גׁ 146	אׁׁ 162	⋯ 178	לׁׁ 194	⌚ 210	Γ 226	≥ 242
3	כׁׁ 131	גׁׁ 147	אׁׁׁ 163	 179	לׁׁׁ 195	⌚ 211	π 227	≤ 243
4	כׁׁׁ 132	גׁׁׁ 148	אׁׁׁׁ 164	┆ 180	— 196	⌚ 212	Σ 228	∫ 244
5	כׁׁׁׁ 133	גׁׁׁׁ 149	אׁׁׁׁׁ 165	⌚ 181	⌚ 197	⌚ 213	σ 229	∫ 245
6	כׁׁׁׁׁ 134	גׁׁׁׁׁ 150	אׁׁׁׁׁׁ 166	⌚ 182	⌚ 198	⌚ 214	μ 230	÷ 246
7	כׁׁׁׁׁׁ 135	גׁׁׁׁׁׁ 151	אׁׁׁׁׁׁׁ 167	⌚ 183	⌚ 199	⌚ 215	τ 231	≈ 247
8	כׁׁׁׁׁׁׁ 136	גׁׁׁׁׁׁׁ 152	אׁׁׁׁׁׁׁׁ 168	⌚ 184	⌚ 200	⌚ 216	Φ 232	° 248
9	כׁׁׁׁׁׁׁׁ 137	גׁׁׁׁׁׁׁׁ 153	אׁׁׁׁׁׁׁׁׁ 169	⌚ 185	⌚ 201	⌚ 217	Θ 233	· 249
A	כׁׁׁׁׁׁׁׁׁ 138	גׁׁׁׁׁׁׁׁׁ 154	אׁׁׁׁׁׁׁׁׁׁ 170	⌚ 186	⌚ 202	⌚ 218	Ω 234	· 250
B	כׁׁׁׁׁׁׁׁׁׁ 139	גׁׁׁׁׁׁׁׁׁׁ 155	אׁׁׁׁׁׁׁׁׁׁׁ 171	⌚ 187	⌚ 203	■ 219	δ 235	√ 251
C	כׁׁׁׁׁׁׁׁׁׁׁ 140	גׁׁׁׁׁׁׁׁׁׁׁ 156	אׁׁׁׁׁׁׁׁׁׁׁׁ 172	⌚ 188	⌚ 204	■ 220	∞ 236	ⁿ 252
D	כׁׁׁׁׁׁׁׁׁׁׁׁ 141	גׁׁׁׁׁׁׁׁׁׁׁׁ 157	אׁׁׁׁׁׁׁׁׁׁׁׁׁ 173	⌚ 189	= 205	■ 221	φ 237	² 253
E	כׁׁׁׁׁׁׁׁׁׁׁׁׁ 142	גׁׁׁׁׁׁׁׁׁׁׁׁׁ 158	אׁׁׁׁׁׁׁׁׁׁׁׁׁׁ 174	⌚ 190	⌚ 206	■ 222	ε 238	■ 254
F	כׁׁׁׁׁׁׁׁׁׁׁׁׁׁ 143	גׁׁׁׁׁׁׁׁׁׁׁׁׁׁ 159	אׁׁׁׁׁׁׁׁׁׁׁׁׁׁׁ 175	⌚ 191	⌚ 207	■ 223	∩ 239	SP 255

HEX	8	9	A	B	C	D	E	F
0	° 128	β 144	SP 160	◌ 176	ϕ 192	ذ 208	- 224	? 240
1	◌ 129	∞ 145	 161	◌ 177	ء 193	ر 209	ف 225	? 241
2	◌ 130	φ 146	آ 162	٢ 178	آ 194	ز 210	ق 226	ن 242
3	√ 131	± 147	£ 163	٣ 179	أ 195	ع 211	ك 227	ه 243
4	 132	½ 148	¤ 164	٤ 180	ؤ 196	ث 212	ل 228	ه 244
5	— 133	¼ 149	أ 165	ه 181	ع 197	لا 213	م 229	ي 245
6	 134	≈ 150	SP 166	٦ 182	ذ 198	ظ 214	ن 230	ي 246
7	† 135	« 151	€ 167	٧ 183	ا 199	ط 215	ه 231	غ 247
8	‡ 136	» 152	ا 168	٨ 184	ب 200	ظ 216	و 232	ق 248
9	⊤ 137	لا 153	ب 169	٩ 185	ة 201	ء 217	ي 233	لا 249
A	⊥ 138	لا 154	ت 170	ف 186	ت 202	غ 218	ي 234	لا 250
B	⊥ 139	SP 155	ث 171	؛ 187	ث 203	ا 219	ض 235	ل 251
C	⊥ 140	SP 156	، 172	س 188	ج 204	ا 220	ع 236	ك 252
D	⊥ 141	لا 157	ج 173	ش 189	ح 205	÷ 221	غ 237	ي 253
E	⊥ 142	لا 158	ح 174	ص 190	خ 206	× 222	غ 238	■ 254
F	⊥ 143	ء 159	خ 175	? 191	د 207	ع 223	م 239	SP 255

Page 38 (PC869: Greek)

HEX	8	9	A	B	C	D	E	F
0	SP 128	Ì 144	ï 160	☐ 176	Ł 192	Ŧ 208	ζ 224	240
1	SP 129	Ï 145	ï̇ 161	☐ 177	⊥ 193	Υ 209	η 225	± 241
2	SP 130	Ŏ 146	ó 162	☐ 178	Ŧ 194	Φ 210	θ 226	υ 242
3	SP 131	SP 147	ú 163	 179	† 195	Χ 211	ι 227	φ 243
4	SP 132	SP 148	Α 164	‡ 180	— 196	Ψ 212	κ 228	χ 244
5	SP 133	Υ 149	Β 165	Κ 181	† 197	Ω 213	λ 229	§ 245
6	À 134	ÿ 150	Γ 166	Λ 182	Π 198	α 214	μ 230	ψ 246
7	€ 135	© 151	Δ 167	Μ 183	Ρ 199	β 215	ν 231	™ 247
8	· 136	Ω 152	Ε 168	Ν 184	ℒ 200	γ 216	ξ 232	° 248
9	¬ 137	² 153	Ζ 169	‡ 185	Ɔ 201	Ɔ 217	ο 233	™ 249
A	¡ 138	³ 154	Η 170	 186	⊥ 202	Γ 218	π 234	ω 250
B	‘ 139	ά 155	½ 171	‡ 187	⊥ 203	■ 219	ρ 235	ü 251
C	’ 140	£ 156	Θ 172	‡ 188	‡ 204	■ 220	σ 236	ÿ 252
D	Έ 141	έ 157	Ι 173	≡ 189	= 205	δ 221	ς 237	ώ 253
E	— 142	ή 158	« 174	Ο 190	‡ 206	ε 222	τ 238	■ 254
F	Ή 143	ì 159	» 175	γ 191	Σ 207	■ 223	’ 239	SP 255

HEX	8	9	A	B	C	D	E	F
0	☐ 128	Ł 144	SP 160	° 176	Ř 192	Đ 208	ř 224	ď 240
1	☐ 129	Ł̇ 145	Ą 161	ą 177	Á 193	Ń 209	á 225	ń 241
2	☐ 130	Ț 146	˘ 162	˙ 178	Â 194	Ň 210	â 226	ň 242
3	 131	Ț̇ 147	Ł̇ 163	ł̇ 179	Ă 195	Ó 211	ă 227	ó 243
4	† 132	— 148	α 164	´ 180	Ä 196	Ô 212	ä 228	ô 244
5	Ј 133	† 149	Ĺ 165	ĺ 181	Í 197	Ŏ 213	í 229	ï 245
6	Г 134	■ 150	Ś 166	ś 182	Ć 198	Ö 214	ć 230	ö 246
7	■ 135	■ 151	Ş 167	˘ 183	Ç 199	× 215	ç 231	÷ 247
8	© 136	Ł̈ 152	ˆ 168	˙ 184	Č 200	Ř̇ 216	č 232	ř̇ 248
9	 137	Ɔ 153	Š 169	š 185	É 201	Û 217	é 233	û 249
A	 138	Ɔ̇ 154	Ş̇ 170	ş̇ 186	Ę 202	Ú 218	ę 234	ú 250
B	 139	Ɔ̇ 155	Ť 171	ť 187	Ě 203	Ů 219	ě 235	ů 251
C	 140	Ɔ̇ 156	Ž 172	ž 188	Ě̇ 204	Ü 220	ě̇ 236	ü 252
D	¢ 141	= 157	ˆ 173	˙ 189	Í 205	Ý 221	í 237	ý 253
E	¥ 142	Ɔ̈ 158	Ž̇ 174	ž̇ 190	Î 206	Ț̇ 222	î 238	ț̇ 254
F	ſ 143	® 159	Ž̈ 175	ž̈ 191	Ď 207	ß 223	ď 239	· 255

Page 40 (ISO8859-15: Latin9)

HEX	8	9	A	B	C	D	E	F
0	SP 128	SP 144	SP 160	° 176	À 192	Ð 208	à 224	ð 240
1	SP 129	SP 145	¡ 161	± 177	Á 193	Ñ 209	á 225	ñ 241
2	SP 130	SP 146	¢ 162	² 178	Â 194	Ò 210	â 226	ò 242
3	SP 131	SP 147	£ 163	³ 179	Ã 195	Ó 211	ã 227	ó 243
4	SP 132	SP 148	€ 164	Ž 180	Ä 196	Ô 212	ä 228	ô 244
5	SP 133	SP 149	¥ 165	µ 181	Å 197	Õ 213	å 229	õ 245
6	SP 134	SP 150	Š 166	¶ 182	Æ 198	Ö 214	æ 230	ö 246
7	SP 135	SP 151	§ 167	· 183	Ç 199	× 215	ç 231	÷ 247
8	SP 136	SP 152	š 168	ž 184	È 200	Ø 216	è 232	ø 248
9	SP 137	SP 153	© 169	¹ 185	É 201	Ù 217	é 233	ù 249
A	SP 138	SP 154	ª 170	º 186	Ê 202	Ú 218	ê 234	ú 250
B	SP 139	SP 155	« 171	» 187	Ë 203	Û 219	ë 235	û 251
C	SP 140	SP 156	¬ 172	Œ 188	Ì 204	Ü 220	ì 236	ü 252
D	SP 141	SP 157	173	œ 189	Í 205	Ý 221	í 237	ý 253
E	SP 142	SP 158	® 174	ÿ 190	Î 206	Þ 222	î 238	þ 254
F	SP 143	SP 159	175	ı 191	Ï 207	ß 223	ï 239	ÿ 255









HEX	8	9	A	B	C	D	E	F
0	SP 128	ؤ 144	ح 160	◻ 176	ل 192	ع 208	ک 224	240
1	SP 129	ئ 145	خ 161	◻ 177	ل 193	ء 209	ک 225	ی 241
2	، 130	ب 146	ذ 162	◻ 178	ت 194	ع 210	گ 226	پ 242
3	؛ 131	ب 147	د 163	 179	ت 195	غ 211	گ 227	- 243
4	؟ 132	ب 148	ذ 164	 180	- 196	غ 212	ل 228	۰ 244
5	ء 133	پ 149	ر 165	ض 181	ت 197	غ 213	ل 229	۱ 245
6	آ 134	ت 150	ز 166	ض 182	ظ 198	غ 214	م 230	۲ 246
7	آ 135	ت 151	ژ 167	ط 183	ع 199	ف 215	م 231	۳ 247
8	آ 136	ت 152	س 168	ط 184	ع 200	ف 216	ن 232	۴ 248
9	ا 137	ث 153	ع 169	ط 185	ع 201	ل 217	ن 233	۵ 249
A	ا 138	ج 154	ش 170	ط 186	ع 202	ل 218	و 234	۶ 250
B	ا 139	چ 155	ش 171	ط 187	ع 203	ل 219	ه 235	۷ 251
C	ء 140	چ 156	ص 172	ط 188	ع 204	ل 220	ه 236	۸ 252
D	أ 141	چ 157	ط 173	ط 189	= 205	ق 221	ه 237	۹ 253
E	أ 142	خ 158	« 174	ظ 190	ع 206	ق 222	ه 238	■ 254
F	آ 143	ح 159	» 175	ط 191	SP 207	■ 223	ی 239	SP 255

Page 42 (PC1118: Lithuanian)

HEX	8	9	A	B	C	D	E	F
0	Ç 128	É 144	á 160	☼ 176	Ł 192	ą 208	α 224	≡ 240
1	ü 129	æ 145	í 161	☼ 177	⊥ 193	č 209	β 225	± 241
2	é 130	Æ 146	ó 162	☼ 178	⊥ 194	ę 210	Γ 226	≥ 242
3	â 131	ô 147	ú 163	 179	† 195	è 211	π 227	≤ 243
4	ä 132	ö 148	ñ 164	† 180	– 196	ì 212	Σ 228	” 244
5	à 133	ò 149	Ñ 165	À 181	† 197	š 213	σ 229	“ 245
6	å 134	û 150	ª 166	Č 182	Û 198	ų 214	μ 230	÷ 246
7	ç 135	ù 151	º 167	Ě 183	Ū 199	ū 215	τ 231	≈ 247
8	ê 136	ÿ 152	¿ 168	É 184	Ł 200	ž 216	Φ 232	° 248
9	ë 137	Ö 153	ƒ 169	‡ 185	Ɔ 201	Ɔ 217	Θ 233	· 249
A	è 138	Ü 154	ƒ 170	‡ 186	Ł 202	Ɔ 218	Ω 234	· 250
B	ï 139	ç 155	½ 171	‡ 187	Ɔ 203	■ 219	δ 235	√ 251
C	î 140	£ 156	¼ 172	‡ 188	Ɔ 204	■ 220	∞ 236	ⁿ 252
D	ì 141	¥ 157	ı 173	ł 189	= 205	■ 221	φ 237	² 253
E	Ä 142	Ɔ 158	« 174	Š 190	‡ 206	■ 222	ε 238	■ 254
F	Å 143	f 159	» 175	ŀ 191	Ž 207	■ 223	∩ 239	SP 255

HEX	8	9	A	B	C	D	E	F
0	A 128	P 144	a 160	☐ 176	L 192	ą 208	p 224	ė 240
1	Б 129	С 145	б 161	☐ 177	⊥ 193	č 209	c 225	ë 241
2	В 130	Т 146	в 162	☐ 178	⊥ 194	ę 210	т 226	≥ 242
3	Г 131	У 147	г 163	 179	⊥ 195	ė 211	y 227	≤ 243
4	Д 132	Ф 148	д 164	⊥ 180	— 196	ì 212	φ 228	” 244
5	Е 133	Х 149	e 165	Ą 181	⊥ 197	š 213	x 229	“ 245
6	Ж 134	Ц 150	ж 166	Č 182	У 198	ų 214	ц 230	÷ 246
7	З 135	Ч 151	з 167	Ę 183	Ū 199	ū 215	ч 231	≈ 247
8	И 136	Ш 152	и 168	Ė 184	Ł 200	ž 216	ш 232	° 248
9	Й 137	Щ 153	й 169	Į 185	Г 201	Ј 217	щ 233	· 249
A	К 138	Ъ 154	к 170	 186	Ł 202	Г 218	ъ 234	· 250
B	Л 139	Ы 155	л 171	Ṛ 187	Ṛ 203	■ 219	ы 235	√ 251
C	М 140	Ь 156	м 172	Ṛ 188	Ṛ 204	■ 220	ь 236	ⁿ 252
D	Н 141	Э 157	н 173	l 189	= 205	■ 221	э 237	² 253
E	О 142	Ю 158	о 174	Š 190	Ṛ 206	■ 222	ю 238	■ 254
F	П 143	Я 159	п 175	Ṛ 191	Ž 207	■ 223	я 239	SP 255

Page 44 (PC1125: Ukrainian)

HEX	8	9	A	B	C	D	E	F
0	А 128	Р 144	а 160	 176	Л 192	л 208	р 224	Є 240
1	Б 129	С 145	б 161	 177	Л 193	л 209	с 225	є 241
2	В 130	Т 146	в 162	 178	Т 194	т 210	т 226	ґ 242
3	Г 131	У 147	г 163	 179	т 195	л 211	у 227	ґ 243
4	Д 132	Ф 148	д 164	† 180	— 196	л 212	ф 228	Є 244
5	Е 133	Х 149	е 165	† 181	† 197	ґ 213	х 229	є 245
6	Ж 134	Ц 150	ж 166	 182	ґ 198	г 214	ц 230	і 246
7	З 135	Ч 151	з 167	т 183	 199	 215	ч 231	і 247
8	И 136	Ш 152	и 168	ґ 184	л 200	† 216	ш 232	ї 248
9	Й 137	Щ 153	й 169	 185	ґ 201	л 217	щ 233	ї 249
A	К 138	Ъ 154	к 170	 186	л 202	г 218	ъ 234	÷ 250
B	Л 139	Ы 155	л 171	т 187	т 203	 219	ы 235	± 251
C	М 140	Ь 156	м 172	л 188	л 204	 220	ь 236	№ 252
D	Н 141	Э 157	н 173	л 189	= 205	 221	э 237	¤ 253
E	О 142	Ю 158	о 174	л 190	 206	 222	ю 238	■ 254
F	П 143	Я 159	п 175	т 191	л 207	 223	я 239	SP 255

HEX	8	9	A	B	C	D	E	F
0	€ 128	SP 144	SP 160	° 176	Ř 192	Đ 208	ř 224	ď 240
1	SP 129	‘ 145	˘ 161	± 177	Á 193	Ń 209	á 225	ń 241
2	, 130	, 146	˘ 162	˘ 178	Â 194	Ň 210	â 226	ň 242
3	SP 131	“ 147	Ł 163	ł 179	Ă 195	Ó 211	ă 227	ó 243
4	” 132	” 148	α 164	’ 180	Ä 196	Ô 212	ä 228	ô 244
5	... 133	• 149	Ą 165	μ 181	Ł 197	Ő 213	í 229	ő 245
6	† 134	– 150	ı 166	¶ 182	Ć 198	Ö 214	ć 230	ö 246
7	‡ 135	— 151	§ 167	· 183	Ç 199	× 215	ç 231	÷ 247
8	SP 136	SP 152	” 168	, 184	Č 200	Ř 216	č 232	ř 248
9	‰ 137	™ 153	© 169	ą 185	É 201	Û 217	é 233	ű 249
A	Š 138	š 154	Ş 170	ş 186	Ę 202	Ú 218	ę 234	ú 250
B	‹ 139	› 155	« 171	» 187	Ě 203	Ů 219	ě 235	ů 251
C	Ś 140	ś 156	¬ 172	Ĺ 188	Ě 204	Ü 220	ę 236	ü 252
D	Ť 141	ť 157	˘ 173	” 189	Í 205	Ý 221	í 237	ý 253
E	Ž 142	ž 158	® 174	Ÿ 190	Î 206	Ț 222	î 238	ț 254
F	Ż 143	ż 159	Ž 175	ż 191	Đ 207	ß 223	đ 239	· 255

Page 46 (WPC1251: Cyrillic)

HEX	8	9	A	B	C	D	E	F
0	Ђ 128	ђ 144	SP 160	° 176	А 192	Р 208	а 224	р 240
1	Ѓ 129	‘ 145	Ў 161	± 177	Б 193	С 209	б 225	с 241
2	, 130	, 146	ў 162	l 178	В 194	Т 210	в 226	т 242
3	ѓ 131	“ 147	Ј 163	i 179	Г 195	У 211	г 227	у 243
4	” 132	” 148	ѡ 164	ѓ 180	Д 196	Ф 212	д 228	ф 244
5	... 133	• 149	Ѓ 165	μ 181	Е 197	Х 213	е 229	х 245
6	† 134	— 150	Ѓ 166	¶ 182	Ж 198	Ц 214	ж 230	ц 246
7	‡ 135	— 151	§ 167	· 183	З 199	Ч 215	з 231	ч 247
8	€ 136	SP 152	Ё 168	ё 184	И 200	Ш 216	и 232	ш 248
9	‰ 137	™ 153	© 169	№ 185	Й 201	Щ 217	й 233	щ 249
A	Љ 138	љ 154	Є 170	є 186	К 202	Ъ 218	к 234	ъ 250
B	‹ 139	› 155	« 171	» 187	Л 203	Ы 219	л 235	ы 251
C	Њ 140	њ 156	ґ 172	j 188	М 204	Ь 220	м 236	ь 252
D	Ќ 141	ќ 157	173	S 189	Н 205	Э 221	н 237	э 253
E	Ў 142	ћ 158	® 174	s 190	О 206	Ю 222	о 238	ю 254
F	Ѡ 143	ѡ 159	Ї 175	ï 191	П 207	Я 223	п 239	я 255

HEX	8	9	A	B	C	D	E	F
0	€ 128	SP 144	SP 160	° 176	ï 192	Π 208	Û 224	π 240
1	SP 129	‘ 145	“ 161	± 177	Α 193	Ρ 209	α 225	ρ 241
2	, 130	’ 146	Ά 162	² 178	Β 194	SP 210	β 226	ς 242
3	f 131	“ 147	£ 163	³ 179	Γ 195	Σ 211	γ 227	σ 243
4	” 132	” 148	α 164	´ 180	Δ 196	Τ 212	δ 228	τ 244
5	... 133	• 149	¥ 165	μ 181	Ε 197	Υ 213	ε 229	υ 245
6	† 134	— 150	¡ 166	¶ 182	Ζ 198	Φ 214	ζ 230	φ 246
7	‡ 135	— 151	§ 167	· 183	Η 199	Χ 215	η 231	χ 247
8	SP 136	SP 152	“ 168	Έ 184	Θ 200	Ψ 216	θ 232	ψ 248
9	‰ 137	™ 153	© 169	Ή 185	Ι 201	Ω 217	ι 233	ω 249
A	SP 138	SP 154	ª 170	Ί 186	Κ 202	Ϊ 218	κ 234	ϊ 250
B	‹ 139	› 155	« 171	» 187	Λ 203	ÿ 219	λ 235	ÿ 251
C	SP 140	SP 156	¬ 172	Ό 188	Μ 204	ά 220	μ 236	ό 252
D	SP 141	SP 157	173	½ 189	Ν 205	έ 221	ν 237	ύ 253
E	SP 142	SP 158	® 174	Υ 190	Ξ 206	ή 222	ξ 238	ώ 254
F	SP 143	SP 159	— 175	Ω 191	Ο 207	ι 223	ο 239	SP 255

Page 48 (WPC1254: Turkish)

HEX	8	9	A	B	C	D	E	F
0	€ 128	SP 144	SP 160	° 176	À 192	Ğ 208	à 224	ğ 240
1	SP 129	' 145	ı 161	± 177	Á 193	Ñ 209	á 225	ñ 241
2	, 130	' 146	ç 162	² 178	Â 194	Ò 210	â 226	ò 242
3	f 131	“ 147	£ 163	³ 179	Ã 195	Ó 211	ã 227	ó 243
4	” 132	” 148	¤ 164	' 180	Ä 196	Ô 212	ä 228	ô 244
5	... 133	• 149	¥ 165	µ 181	Å 197	Õ 213	å 229	õ 245
6	† 134	– 150	ı 166	¶ 182	Æ 198	Ö 214	æ 230	ö 246
7	‡ 135	— 151	§ 167	· 183	Ç 199	× 215	ç 231	÷ 247
8	^ 136	~ 152	¨ 168	¸ 184	È 200	Ø 216	è 232	ø 248
9	‰ 137	™ 153	© 169	¹ 185	É 201	Ù 217	é 233	ù 249
A	Š 138	š 154	ª 170	º 186	Ê 202	Ú 218	ê 234	ú 250
B	‹ 139	› 155	« 171	» 187	Ë 203	Û 219	ë 235	û 251
C	Œ 140	œ 156	¬ 172	¼ 188	Ì 204	Ü 220	ì 236	ü 252
D	SP 141	SP 157	173	½ 189	Í 205	İ 221	í 237	ı 253
E	SP 142	SP 158	® 174	¾ 190	Î 206	Ş 222	î 238	ş 254
F	SP 143	ÿ 159	175	¿ 191	Ï 207	ß 223	ï 239	ÿ 255

HEX	8	9	A	B	C	D	E	F
0	€ 128	SP 144	SP 160	° 176	· 192	ı 208	א 224	ב 240
1	SP 129	‘ 145	ı 161	± 177	“ 193	· 209	ב 225	ו 241
2	, 130	’ 146	¢ 162	² 178	” 194	· 210	ג 226	ז 242
3	f 131	“ 147	£ 163	³ 179	” 195	: 211	ד 227	ח 243
4	” 132	” 148	₪ 164	’ 180	· 196	ן 212	ה 228	ט 244
5	... 133	• 149	¥ 165	μ 181	” 197	ן 213	ו 229	י 245
6	† 134	— 150	ı 166	¶ 182	” 198	” 214	ז 230	כ 246
7	‡ 135	— 151	§ 167	· 183	· 199	’ 215	ח 231	ל 247
8	^ 136	~ 152	” 168	’ 184	” 200	” 216	ט 232	מ 248
9	‰ 137	™ 153	© 169	¹ 185	· 201	SP 217	י 233	נ 249
A	SP 138	SP 154	× 170	÷ 186	SP 202	SP 218	ן 234	ס 250
B	‹ 139	› 155	« 171	» 187	” 203	SP 219	כ 235	SP 251
C	SP 140	SP 156	¬ 172	¼ 188	· 204	SP 220	ל 236	SP 252
D	SP 141	SP 157	· 173	½ 189	· 205	SP 221	ם 237	SP 253
E	SP 142	SP 158	® 174	¾ 190	· 206	SP 222	נ 238	SP 254
F	SP 143	SP 159	— 175	¿ 191	· 207	SP 223	ן 239	SP 255

Page 50 (WPC1256: Arabic)

HEX	8	9	A	B	C	D	E	F
0	€ 128	گ 144	SP 160	° 176	ˆ 192	ذ 208	à 224	´ 240
1	پ 129	‘ 145	‘ 161	± 177	ء 193	ر 209	ل 225	* 241
2	, 130	’ 146	¢ 162	² 178	آ 194	ز 210	â 226	ˆ 242
3	f 131	“ 147	£ 163	³ 179	أ 195	س 211	م 227	ˆ 243
4	” 132	” 148	¤ 164	´ 180	ؤ 196	ش 212	ن 228	ô 244
5	... 133	• 149	¥ 165	µ 181	إ 197	ص 213	ه 229	’ 245
6	† 134	– 150	¡ 166	¶ 182	ئ 198	ض 214	و 230	ˆ 246
7	‡ 135	— 151	§ 167	· 183	ا 199	× 215	ç 231	÷ 247
8	ˆ 136	ک 152	¨ 168	د 184	ب 200	ط 216	è 232	ˆ 248
9	% 137	™ 153	© 169	¹ 185	ة 201	ظ 217	é 233	ù 249
A	ٹ 138	ڑ 154	ھ 170	؛ 186	ت 202	ع 218	ê 234	° 250
B	‹ 139	› 155	« 171	» 187	ث 203	غ 219	ë 235	û 251
C	Œ 140	œ 156	¬ 172	¼ 188	ج 204	- 220	ی 236	ü 252
D	چ 141	SP 157	173	½ 189	ح 205	ف 221	ي 237	SP 253
E	ژ 142	SP 158	® 174	¾ 190	خ 206	ق 222	î 238	SP 254
F	ڈ 143	ں 159	– 175	؟ 191	د 207	ك 223	ï 239	ے 255

HEX	8	9	A	B	C	D	E	F
0	€ 128	SP 144	SP 160	° 176	Ą 192	Š 208	ą 224	š 240
1	SP 129	‘ 145	SP 161	± 177	ł 193	Ń 209	ł 225	ń 241
2	, 130	’ 146	¢ 162	² 178	Ą 194	Ņ 210	ā 226	ņ 242
3	SP 131	“ 147	£ 163	³ 179	Ć 195	Ó 211	ć 227	ó 243
4	” 132	” 148	¤ 164	´ 180	Ä 196	Õ 212	ä 228	õ 244
5	... 133	• 149	SP 165	μ 181	Ą 197	Õ 213	ą 229	õ 245
6	† 134	– 150	ı 166	¶ 182	Ę 198	Ö 214	ę 230	ö 246
7	‡ 135	— 151	§ 167	· 183	Ę 199	× 215	ę 231	÷ 247
8	SP 136	SP 152	Ø 168	ø 184	Č 200	Ț 216	č 232	ț 248
9	‰ 137	™ 153	© 169	¹ 185	É 201	Ł 217	é 233	ł 249
A	SP 138	SP 154	Ŕ 170	ŗ 186	Ż 202	Ś 218	ż 234	ś 250
B	‹ 139	› 155	« 171	» 187	Ě 203	Ū 219	ě 235	ū 251
C	SP 140	SP 156	¬ 172	¼ 188	Ğ 204	Ü 220	ğ 236	ü 252
D	¨ 141	– 157	173	½ 189	Ķ 205	Ž 221	ķ 237	ž 253
E	˘ 142	˙ 158	® 174	¾ 190	Ī 206	Ž 222	ī 238	ž 254
F	˚ 143	SP 159	Æ 175	æ 191	Ł 207	ß 223	ł 239	· 255

Page 52 (WPC1258: Vientamese)

HEX	8	9	A	B	C	D	E	F
0	€ 128	SP 144	SP 160	° 176	À 192	Đ 208	à 224	đ 240
1	SP 129	‘ 145	ì 161	± 177	Á 193	Ñ 209	á 225	ñ 241
2	, 130	’ 146	ç 162	² 178	Â 194	ˆ 210	â 226	ˆ 242
3	f 131	“ 147	£ 163	³ 179	Ă 195	Ó 211	ă 227	ó 243
4	” 132	” 148	¤ 164	´ 180	Ä 196	Ô 212	ä 228	ô 244
5	... 133	• 149	¥ 165	µ 181	Å 197	Õ 213	å 229	õ 245
6	† 134	– 150	¦ 166	¶ 182	Æ 198	Ö 214	æ 230	ö 246
7	‡ 135	— 151	§ 167	· 183	Ç 199	× 215	ç 231	÷ 247
8	^ 136	˜ 152	¨ 168	¸ 184	È 200	Ø 216	è 232	ø 248
9	‰ 137	™ 153	© 169	¹ 185	É 201	Ù 217	é 233	ù 249
A	SP 138	SP 154	ª 170	º 186	Ê 202	Ú 218	ê 234	ú 250
B	‹ 139	› 155	« 171	» 187	Ë 203	Û 219	ë 235	û 251
C	Œ 140	œ 156	¬ 172	¼ 188	ˆ 204	Ü 220	ˆ 236	ü 252
D	SP 141	SP 157	173	½ 189	Í 205	Ů 221	í 237	ů 253
E	SP 142	SP 158	® 174	¾ 190	Î 206	˘ 222	î 238	đ 254
F	SP 143	ÿ 159	175	¿ 191	Ï 207	ß 223	ï 239	ÿ 255

HEX	8	9	A	B	C	D	E	F
0	Љ 128	ђ 144	SP 160	° 176	А 192	Р 208	а 224	р 240
1	ѓ 129	‘ 145	Ў 161	± 177	Б 193	С 209	б 225	с 241
2	, 130	’ 146	ў 162	l 178	В 194	Т 210	в 226	т 242
3	ѓ 131	“ 147	Ә 163	i 179	Г 195	У 211	г 227	у 243
4	” 132	” 148	ӑ 164	ө 180	Д 196	Ф 212	д 228	ф 244
5	... 133	• 149	Ө 165	μ 181	Е 197	Х 213	е 229	х 245
6	† 134	– 150	ı 166	¶ 182	Ж 198	Ц 214	ж 230	ц 246
7	‡ 135	— 151	§ 167	· 183	З 199	Ч 215	з 231	ч 247
8	€ 136	SP 152	Ё 168	ё 184	И 200	Ш 216	и 232	ш 248
9	‰ 137	™ 153	© 169	№ 185	Й 201	Щ 217	й 233	щ 249
A	Ў 138	ў 154	Ғ 170	ғ 186	К 202	Ъ 218	к 234	ъ 250
B	‹ 139	› 155	« 171	» 187	Л 203	Ы 219	л 235	ы 251
C	Ң 140	ң 156	Ҝ 172	ө 188	М 204	Ь 220	м 236	ь 252
D	Қ 141	қ 157	- 173	Ҙ 189	Н 205	Э 221	н 237	э 253
E	Һ 142	һ 158	® 174	Ң 190	О 206	Ю 222	о 238	ю 254
F	Ҙ 143	Ҙ 159	Ү 175	ү 191	П 207	Я 223	п 239	я 255

Page 255 (User-Defined Page)

HEX	8	9	A	B	C	D	E	F
0	SP 128	SP 144	SP 160	SP 176	SP 192	SP 208	SP 224	SP 240
1	SP 129	SP 145	SP 161	SP 177	SP 193	SP 209	SP 225	SP 241
2	SP 130	SP 146	SP 162	SP 178	SP 194	SP 210	SP 226	SP 242
3	SP 131	SP 147	SP 163	SP 179	SP 195	SP 211	SP 227	SP 243
4	SP 132	SP 148	SP 164	SP 180	SP 196	SP 212	SP 228	SP 244
5	SP 133	SP 149	SP 165	SP 181	SP 197	SP 213	SP 229	SP 245
6	SP 134	SP 150	SP 166	SP 182	SP 198	SP 214	SP 230	SP 246
7	SP 135	SP 151	SP 167	SP 183	SP 199	SP 215	SP 231	SP 247
8	SP 136	SP 152	SP 168	SP 184	SP 200	SP 216	SP 232	SP 248
9	SP 137	SP 153	SP 169	SP 185	SP 201	SP 217	SP 233	SP 249
A	SP 138	SP 154	SP 170	SP 186	SP 202	SP 218	SP 234	SP 250
B	SP 139	SP 155	SP 171	SP 187	SP 203	SP 219	SP 235	SP 251
C	SP 140	SP 156	SP 172	SP 188	SP 204	SP 220	SP 236	SP 252
D	SP 141	SP 157	SP 173	SP 189	SP 205	SP 221	SP 237	SP 253
E	SP 142	SP 158	SP 174	SP 190	SP 206	SP 222	SP 238	SP 254
F	SP 143	SP 159	SP 175	SP 191	SP 207	SP 223	SP 239	SP 255

International Character Sets

Country	ASCII code (Hex)													
	23	24	25	2A	40	5B	5C	5D	5E	60	7B	7C	7D	7E
USA	#	\$	%	*	@	[¥]	^	`	{		}	~
France	#	\$	%	*	à	°	ç	§	^	`	é	ù	è	¨
Germany	#	\$	%	*	§	Ä	Ö	Ü	^	`	ä	ö	ü	ß
U.K.	£	\$	%	*	@	[¥]	^	`	{		}	~
Denmark I	#	\$	%	*	@	Æ	Ø	Å	^	`	æ	ø	å	~
Sweden	#	¤	%	*	É	Ä	Ö	Å	Ü	é	ä	ö	å	ü
Italy	#	\$	%	*	@	°	¥	é	^	ù	à	ò	è	ì
Spain I	Pt	\$	%	*	@	ı	Ñ	ı	^	`	¨	ñ	}	~
Japan	#	\$	%	*	@	[¥]	^	`	{		}	~
Norway	#	¤	%	*	É	Æ	Ø	Å	Ü	é	æ	ø	å	ü
Denmark II	#	\$	%	*	É	Æ	Ø	Å	Ü	é	æ	ø	å	ü
Spain II	#	\$	%	*	á	ı	Ñ	ı	é	`	ı	ñ	ó	ú
Latin America	#	\$	%	*	á	ı	Ñ	ı	é	ü	ı	ñ	ó	ú
Korea	#	\$	%	*	@	[₩]	^	`	{		}	~
Slovenia/Croatia	#	\$	%	*	Ž	Š	Đ	Ć	Č	ž	š	đ	ć	č
China	#	¥	%	*	@	[¥]	^	`	{		}	~
Vietnam	đ	\$	%	*	@	[¥]	^	`	{		}	~
Arabia	#	\$	%	*	@	[¥]	^	`	{		}	~